



SafeZone™
safer. simpler. smarter.



SafeZone™
Standard / LDS / MDS
Installation Manual (Version 1.25)

CALL NOW 1300 885 364

Jaybro.com.au

Copyright

Copyright © 2023 Jaybro Group™. All rights reserved.

This manual may be reproduced in its entirety for the express purpose of training, installation, submission or any other purpose that furthers the use of this product, safe use of the product and the safety of those using the product. The manual can only be reproduced as a complete copy so there is no misunderstanding or misuse of the product.

Disclaimer

All contents of this document are subject to change without notice and do not represent a commitment on the part of Jaybro Group. Every effort is made to ensure the accuracy of this information. However, due to ongoing product improvements and revisions, Jaybro Group cannot guarantee the accuracy of this material, nor can it accept responsibility for errors or omissions. No warranties of any nature are extended by the information contained in this manual.

All names, products, and services mentioned herein are the trademarks or registered trademarks of their respective organisations and are the sole property of their respective owners.

SafeZone™ is a registered trade name of Jaybro Group in Australia and New Zealand.

Contact Details

Ben Lorne

Business Development Manager - Fortress & Barriers

ben.lorne@Jaybro.com.au

0436 638 792

Table of Contents

Item	Page
1 Introduction	4
2 Safety statements	8
3 Impact attenuators and transitions	9
4 Common components list	10
5 Anchor Foundation Specifications & Material Specifications	11
6 Required tools	13
7 Anchoring options on asphalt and concrete	13
8 Standard installation on asphalt using Pin Type A	15
9 SafeZone Limited Deflection System	20
10 Anchoring options on asphalt and concrete for Limited Deflection System	21
11 SafeZone Limited Deflection System Installation using Pin Type B	22
12 SafeZone Minimum Deflection System	29
13 Anchoring options on asphalt and concrete for Minimum Deflection System	30
14 SafeZone Minimum Deflection System Installation using Pin Type B	31
15 Maintenance and repair	38
16 Removal	39
17 Permanent installations	40
18 Limitations and warnings	41
19 Lifting Guide 5.8m barrier	42
20 Lifting Guide 11.6m barrier	43
21 Lifting Guide ForkLift	44
22 Marking	45
Example pre-installation checklist	46
Example installation form	47
Annex 1: SafeZone Drawings	
Annex2: Compatible Crash Cushions available	

1. Introduction

1.1. General

SafeZone™ is a rapidly deployable Steel Safety Barrier conforming to AASHTO Manual for Assessing Safety Hardware (MASH).

The MASH specification is an update to and supersedes NCHRP Report 350 for the purposes of evaluating new safety hardware devices. MASH is also the basis of testing procedures for road safety systems as stated in AS/NZS 3845.1: 2015 Road Safety Barrier System and Devices. The introduction of MASH follows changes to the vehicle fleet, researching of real-life impact conditions and updated criteria for evaluating barrier performance.

SafeZone™ is a smooth faced modular vehicle restraint system, anchored to the ground at the end of each run or at intermediate anchor points along its length as required to meet site-specified performance requirements. The closed design feature of SafeZone™ eliminates snag points providing consideration for vulnerable road users.

SafeZone™ comprises single, prefabricated 5.8m elements. Two (2) elements are bolted together at the factory prior to deployment, providing 11.6m long sections with male and female Quick Mount connectors to facilitate rapid onsite assembly. Fast connection of the elements is achieved by lining up the barrier and locking the Quick Mount connectors together.

The symmetrical design of SafeZone™ enables it to be deployed as either a single- or double-sided barrier providing protection for verge and median applications. The barrier may be secured to concrete and asphalt road surfaces.

The maximum length of the system is unlimited as the barrier relies upon the combination of torsional rigidity, anchoring and system mass to provide safe vehicle containment and redirection.

The anchoring frequency of SafeZone™ may be adjusted to provide three (3) configuration options:

1. SafeZone™ Standard;
2. SafeZone™ LDS; and
3. SafeZone™ MDS.

1.2. Deflection Chart

Model	Dynamic Deflection	Dynamic Working Width	Length of need	Anchorage
SafeZone TL3 Standard	1.70m	2.06m	69.63m	every 69.6m
SafeZone TL4 Standard	2.07m	2.96m	69.63m	every 69.6m
SafeZone TL3 Limited Deflection	0.42m	1.06m*	40.62m	every 11.6m
SafeZone TL4 Limited Deflection	0.45m	2.17m*	40.62m	every 11.6m
SafeZone TL3 MDS Deflection	169mm	808mm	40.62m	every 5.8m

1.3. Design Considerations

Pavement Grading

It is recommended that the slope of the pavement not exceed a grading of 8% to facilitate controlled vehicle containment and redirection.

Dynamic Deflection

Dynamic deflection is the maximum lateral displacement of the barrier during a vehicle impact. When a vehicle strikes a barrier, the dynamic deflection varies according to the characteristics of the impacting vehicle, including vehicle mass, impact speed, angle of impact and the characteristics of the barrier system. Sufficient dynamic clearance should be provided between the face of the barrier and a hazard to accommodate the appropriate dynamic deflection.

Working Width

The working width is the minimum distance required to prevent an impacting design vehicle from colliding with an object behind a barrier system. This includes both the dynamic deflection of the barrier and the extra width to allow for the roll (vertical rotation) of an impacting vehicle. Working width is an important design consideration when shielding above-ground fixed hazards such as trees, sign supports or bridge piers.

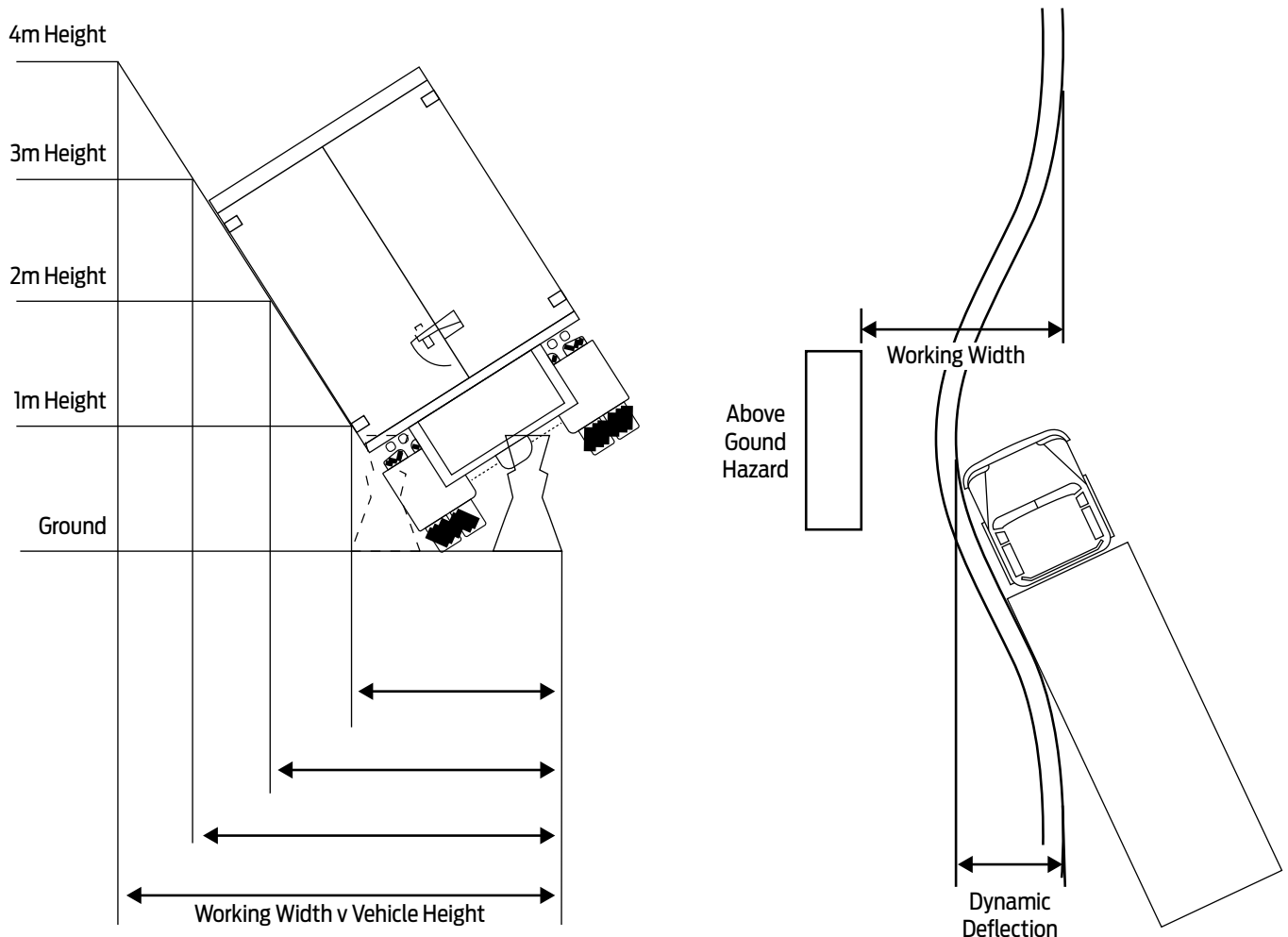

1.4. SafeZone™ Standard

SafeZone™ Standard provides an economical solution for worksites with sufficient clearance behind the system to accommodate expected barrier deflection and working width. The spacing of the anchors is 69.6m allowing the system to be rapidly installed, reducing drilling frequency and subsequent disruption to traffic.



Crash Test Results

Containment Level	Dynamic Deflection	Working Width	Length of Need	Spacing of Anchors
MASH TL3	1.70m	2.06m	69.63m	69.6m
MASH TL4	2.07m	2.96m	69.63m	69.6m

MASH TL4 Working Widths – for Standard Deflection Test

Vehicle Height			
1m	2m	3m	4m
2.48	2.64	2.80	2.96

1.5. SafeZone™ LDS

SafeZone™ Low Deflection System (LDS) features a reduction in the spacing of anchors resulting in lower dynamic deflections and working widths. This is an important design consideration when workers or fixed hazards are located within close proximity to the barrier.



Crash Test Results

Containment Level	Dynamic Deflection	Working Width	Length of Need	Spacing of Anchors
MASH TL3	0.42m	1.06m	40.6m	11.6m
MASH TL4	0.45m	2.17m	40.6m	11.6m

1.6. SafeZone™ MDS

SafeZone™ Minimum Deflection System (MDS) is designed for constrained sites that cannot accommodate the deflections and working widths of SafeZone™ LDS. The spacing of the anchors is reduced to just 5.8m, increasing the stiffness of the system. While providing lower dynamic deflection results, a Minimum Deflection System (MDS) increases the potential for vehicle occupant risk during high-speed impacts due to the increased stiffness of the barrier. It is therefore recommended that MDS installations be limited to constrained sites and undergo risk assessment analysis when preferred to Low Deflection System (LDS) options. The frequency of anchoring throughout the installation may revert to the nominated spacings for SafeZone™ LDS or SafeZone™ Standard where there is sufficient hazard free clearance behind the barrier.



Crash Test Results

Containment Level	Dynamic Deflection	Working Width	Length of Need	Spacing of Anchors
MASH TL3	0.169m	0.808m	40.6m	5.8m

SafeZone TL4 Standard Installation

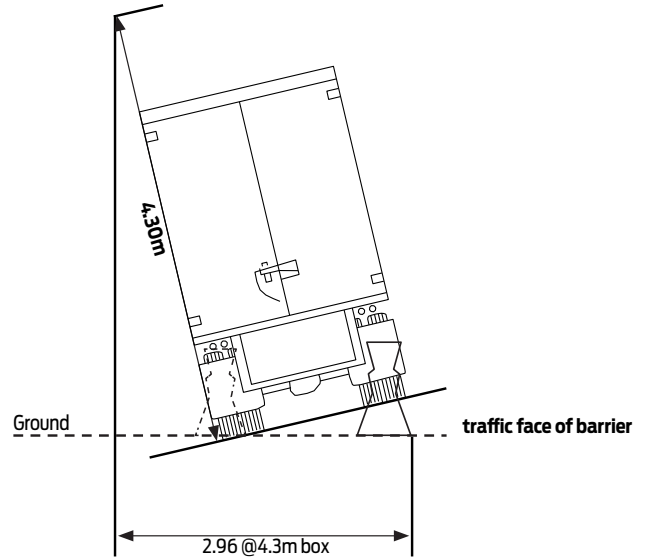
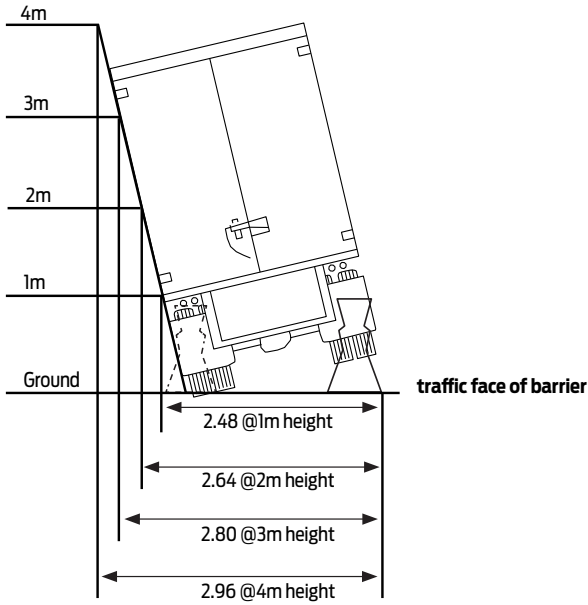

Safezone TL4 Limited Deflection Installation

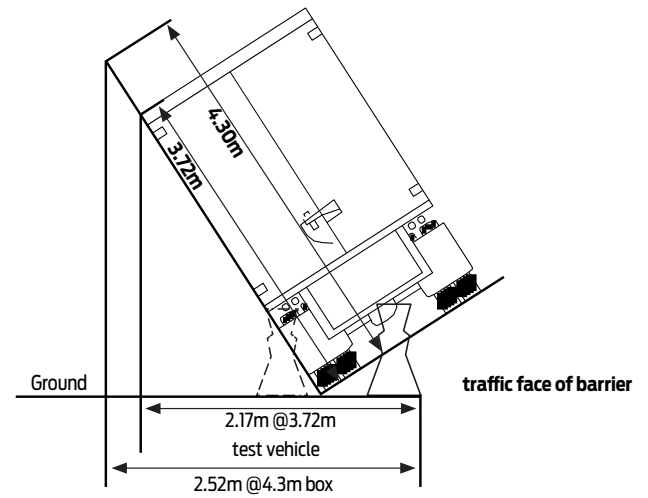
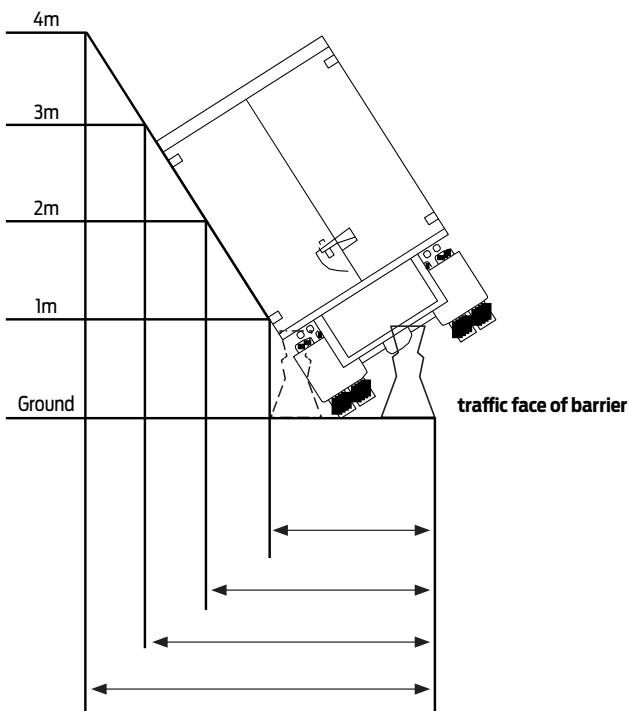

1.7. Table of curvatures

Method	Description	Max. Angle °	Radius (comment)
1	Movement on Quick Connect	0.63	minimum radius using only standard barriers: 528.0m
2	5 degree angle piece	5.0	
3	10 degree angle piece	10.0	minimum radius achievable using only 10° angle pieces: 11.2 m

Depending on the arc length any radius between 11.2m – ∞ can be achieved using the parts in the table above For job specific analysis contact your supplier.

1.8. Delineators

Reflective delineators can be attached to the side wall of the SafeZone™ as required and at the relevant spacings. There are two options of delineators available, one a fixed reflector the second a reflector with a flexible joint which helps makes it resistant to breaking. Reflectors can be also attached on top of the barrier.

2. Safety Statements

2.1. Lifting Safe Zone

Use lifting equipment that apply to local regulations.

Each standard element of SafeZone is 5.8m long and weighs approx. 535kg. It is supplied with two elements bolted together to form one 11.6m unit. The connection of the elements was made by lowering one element over the other. These barrier sections are connected together with male to female pin joints and then locked with a single security bolt. The weight of one unit is approx. **1,070kg**. The standard barrier sections have 3 different lifting options, 1 position for lifting with a forklift and 2 positions for lifting with a crane using chains and hooks.



Make sure the chains are not twisted before hooking on. When hooking on to the barrier, make sure the hook is around the bar that runs across the slot. NEVER HOOK ON TO THE SHEET STEEL DIRECTLY. Make sure the hooks face outwards, i.e. the open side of the hook nearest the end of the barrier. Make sure the properly rated chain + hook for the load.

2.2. Turning the barrier over

In order to stack the barrier it is occasionally necessary to invert the barrier. Do not turn the barrier over by pulling it sideways with the crane. This can cause damage to the crane and chains, which could cause an accident due to failure during subsequent lifting operations. The following method can be used but note that the chain hooks are subject to side load when using this method. Always, therefore, use hooks that are rated at or above (typically 2,000 kg per hook) and use of the conventional type, not the type where the chain attaches to the extended latching bar.

Chapter 14/15/16 Lifting guide

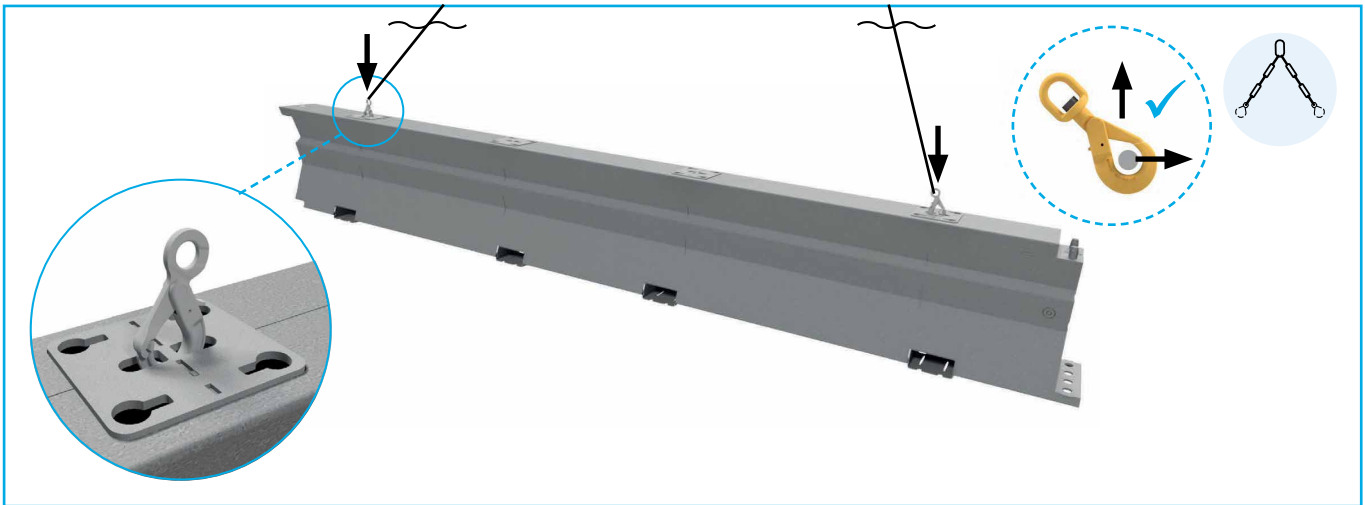

2.3. Inverting the SafeZone

Lower the barrier onto a wooden block so that the barrier settles on the block near the center of the barrier clear of cross members and with only one side of the barrier supported by the block. Continue lowering the barrier until it lies on its side. Transfer the chains from the lifting eyes on the top of the barrier to the lifting eyes on the bottom of the barrier and lift the inverted barrier.

2.4. Righting inverted SafeZone

Lower the barrier onto a timber wedge with approximately a one in three slope. The barrier will settle on its side. Transfer the lifting chains from the bottom of the barrier to the top of the barrier and lift in the normal way.

2.5. General Safety

- All required traffic safety precautions should be followed. All workers should wear required Personal Protective Equipment (PPE) (OSHA approved vest, steel toed boots, eye protection, gloves).
- Only authorised trained personnel should operate any machinery. Where overhead machinery is used, care must be taken to avoid overhead hazards.
- There are no underground services, waterproof membranes etc. which could be damaged by drilling;
- There are no overhead cables that could be contacted by the lifting operation.
- There is adequate working room and safety zone.

3. Impact attenuators and transitions

Depending on state installation requirements SafeZone must start and finish with an approved impact attenuator or end terminal. Details of Impact attenuator transitions and connections are available from the Impact attenuator supplier.

Refer to annex 2 for approved impact attenuators and transitions.

4. Common Components List

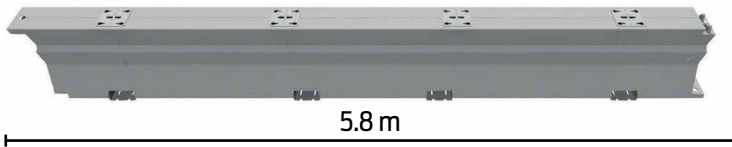

SafeZone 5.8m (19.0ft) section, male/female QuickLink(AS31840000)

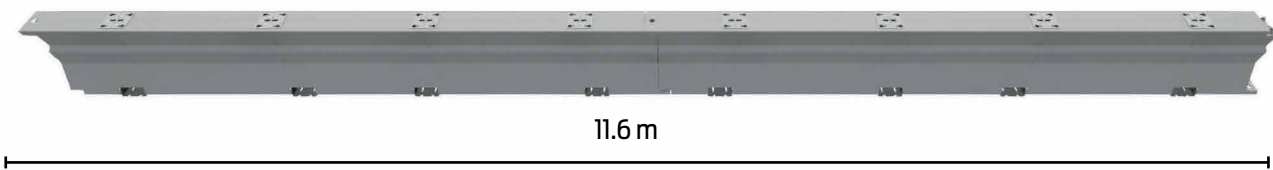

SafeZone 11.6m section, male/female QuickLink, a unit



SafeZone anchor shoe (AS31840020)



SafeZone Flat top pin (AS31642592)



SafeZone Threaded rod 300mm (KE31840030)



SafeZone Threaded rod 175mm (KE31840031)



SafeZone Excalibur bolt 300mm



SafeZone™ with a crash cushion end treatment. Transition should be fitted prior to the Crash Cushion installed. Per the manufacturer's guidelines.

All M20 bolts to be used for connecting sections of SafeZone together to be at least grade 8.8. torque:200Nm (148 ft - lb).

5. Anchor Foundation Specifications & Material Specifications

5.1. Anchor Foundation Specifications

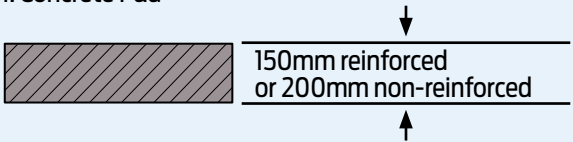
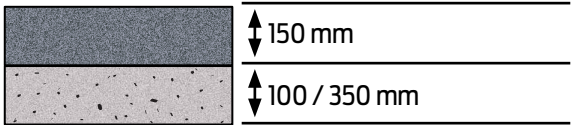
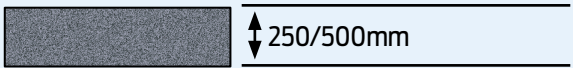
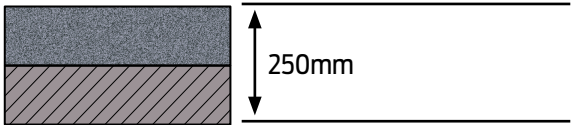
The SafeZone system has been designed to attach to concrete or asphalt foundations. Use the anchorage specified on page 10, depending on the foundation at the specific job site. Other foundations than listed below are not allowed.

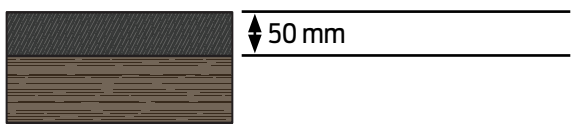
<p>1. Concrete Pad</p> 	<p>Foundation: Min 150mm reinforced pad or 200mm non reinforced pad</p>
<p>2. Asphalt over Base</p> 	<p>Foundation: Min 150mm AC over 100 or 350mm compacted Base 100mm (anchor type B) 350mm (anchor type A)</p>
<p>3. Asphalt only</p> 	<p>Foundation: Min 250mm AC 250mm (anchor type B) 500mm (anchor type A)</p>
<p>4. Asphalt over Concrete</p> 	<p>Foundation: A Cover Concrete Total build up minimum 250mm</p>
<p>5. AASHTO Soil</p> 	<p>Foundation: Min 200mm AASHTO standard soil strength</p>
<p>6. Flush seal over granular pavement</p> 	<p>Foundation: 50mm flush seal over min AASHTO standard soil strength</p>

5.2. Material Specifications

Portland Cement Concrete (PCC)



Stone aggregate concrete mix, 25MPa minimum compressive strength.
 N25 per AS1379 sampling and testing per AS1012.

Asphaltic Concrete (AC)



C450A.C. (Per AS2008) 19.0mm (AC20) maximum,
 coarse aggregate (per AS2891.3.1)

Sieve Size % Passing

26.5mm	100%
19.0mm	80 – 98%
13.2mm	65 – 93%
6.7mm	45 – 70%
2.36mm	20 – 40%
0.600mm	5 – 25%
0.075mm	2 – 8%

Compacted (Sub)Base (DGA)

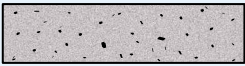

Densely Graded Base course as per local authority standards.
 45mm aggregate maximum
 CBR ≥ 80%

Note: in case of other pavement specifications please consult manufacturer for advice.

6. Required Tools

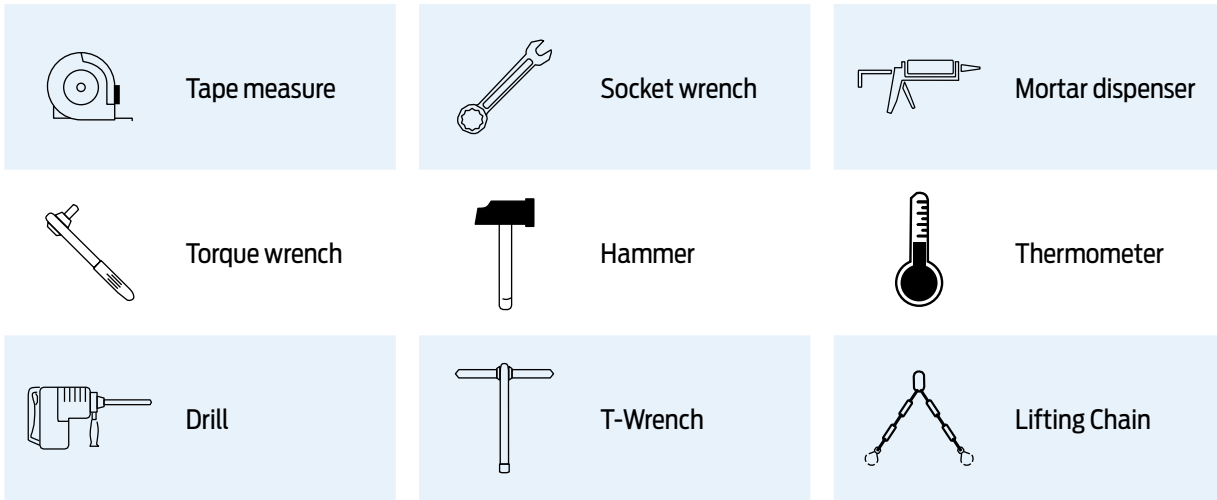

7. Anchoring options on asphalt and concrete

7.1. Foundation Type

Suitable foundation type for Standard System



Foundation Type	Concrete Pad	Asphalt over subbase	Asphalt only	Asphalt over concrete	AASHTO Soil	Flush seal over granular pavement
Anchor shoe type	1	1	1	1	1	1
Anchor pin type	C	A/B/D	A/B	B	A	A

Note: in case of concrete decks thinner than 250mm please consult manufacturer for advice.

7.2. Choice of anchoring

Type 1	Anchor shoe standard (AS31840020)	
--------	-----------------------------------	--

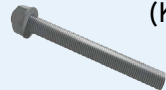
7.3. Anchor Pin

Anchor Pin Type		Diameter Drilled Hole	Anchor Shoe Type	Traffic Side	Non Traffic Side
Type A Flat top pin Ø 30mm Length: 520mm	 (AS31642592)	Ø30mm 500mm depth	Type 1		
Type B Threaded Rod Ø 30mm Length: 300mm	 (KE31840030)	Ø35mm 250mm depth	Type 1		
Type C Threaded Rod Ø 30mm Length: 175mm	 (KE31840031)	Ø35mm 125mm depth	Type 1		
Type D Excalibur Bolt Ø 20mm Length: 300mm	 (not known)	Ø20mm 280mm depth	Type 1		

NOTE:

- Type B anchor pin is a chemical set anchor. Please refer to chapter 10.8 - 10.18 for instructions how to install these chemical anchor pins. Follow the instructions of chapter 7 for anchor distance for the standard installation when using type B anchor pins.
- Type D anchor used for Standard SafeZone TL3 only

7.4. Alternative anchoring systems

Alternative anchoring systems can be used to anchor SafeZone into concrete. Alternative anchoring systems need to comply with the required minimum pull and shear capacity as described below or need an individual approval from the barrier supplier. For the SafeZone Standard System and LDS System in concrete the following minimum anchor capacity is required:

- Pull force capacity, minimum, non-cracked concrete: $NR_{k,c} = 82\text{kN}$ (unfactored) or $NR_{d,c} = 55\text{kN}$ (factored) (concrete cone failure based on C25/30 EN206)
- Pull force capacity, minimum, cracked concrete: $NR_{k,c} = 58\text{kN}$ (unfactored) or $NR_{d,c} = 39\text{kN}$ (factored) (concrete cone failure based on C25/30 EN206)
- Shear force capacity, minimum: $VR_{k,s} = 225\text{ kN}$ (unfactored) or $VR_{d,s} = 180\text{ kN}$ (factored) (steel failure)

8. Standard installation on asphalt using pin type A

8.1. Start with standard SafeZone barrier section (AS31840000)

1

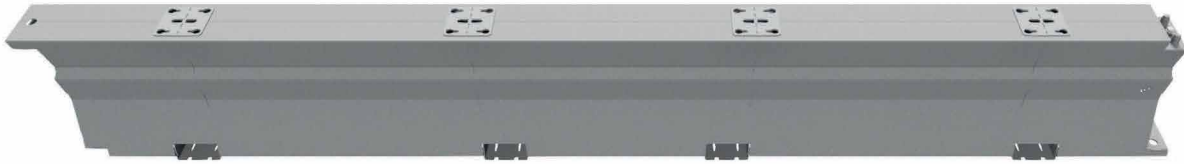



(AS31840000)

The standard installation is anchored on both ends by means of 4 anchors on each end. The minimum installation length of SafeZone Standard System is 69.63 m.

8.2. Beginning of first string of barriers

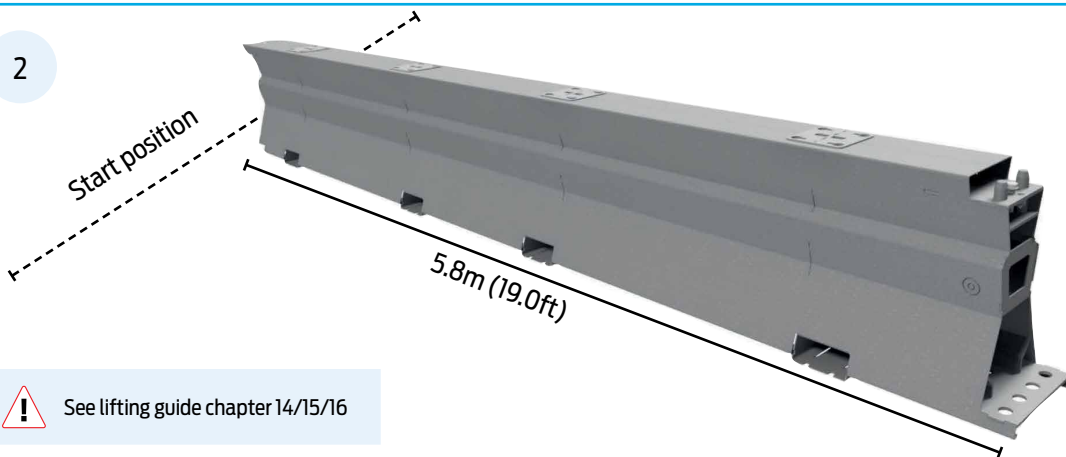
2



 See lifting guide chapter 14/15/16

8.3. The male coupling including the security bolt must face down stream

3

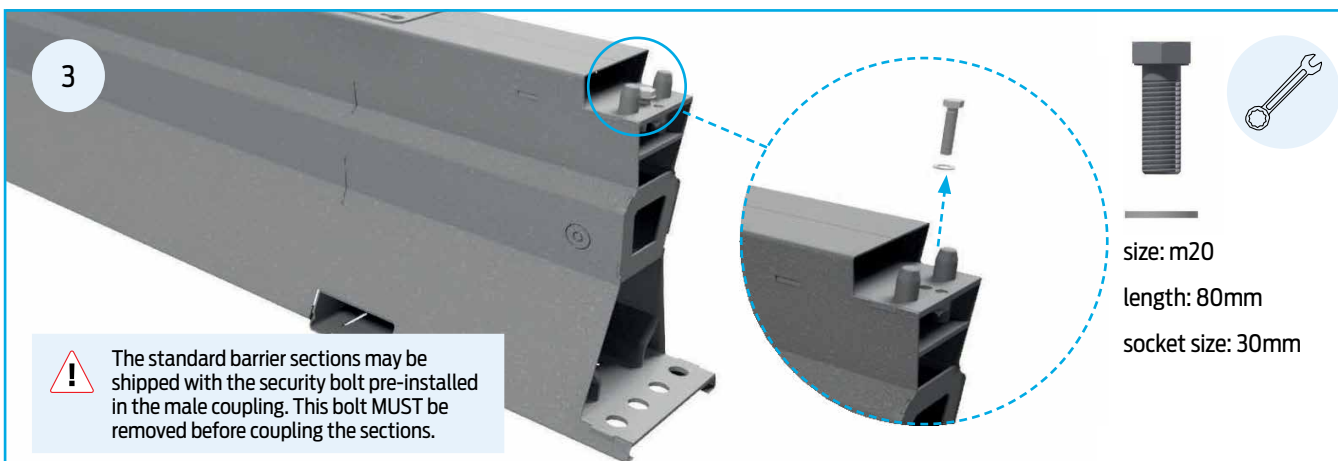

 The standard barrier sections may be shipped with the security bolt pre-installed in the male coupling. This bolt **MUST** be removed before coupling the sections.

size: m20
length: 80mm
socket size: 30mm

8.4. Lower one element over the other

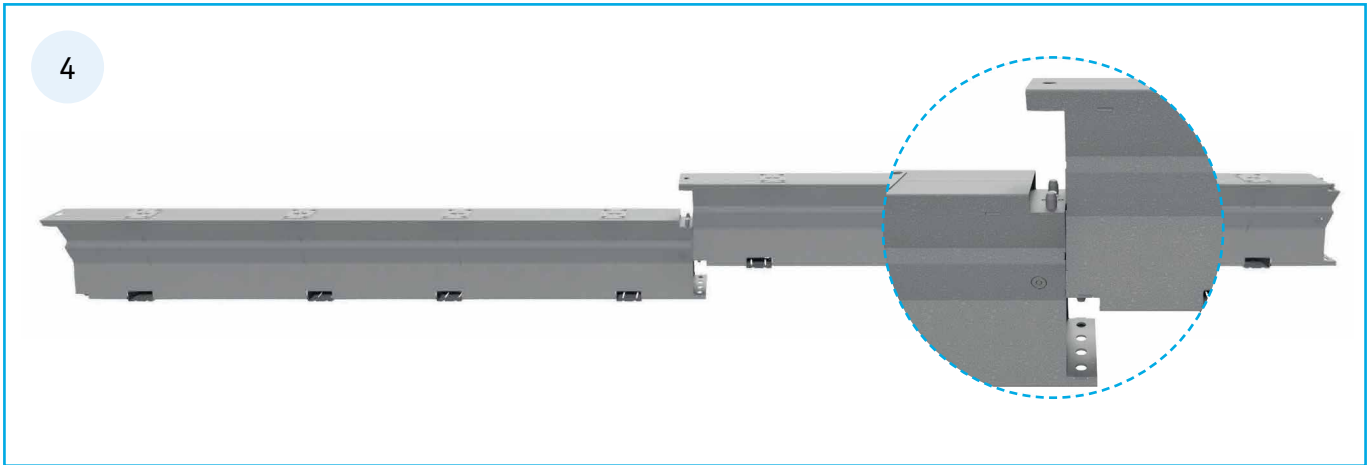

8.5. Lock the sections together with the security bolt using the ratchet or T-wrench

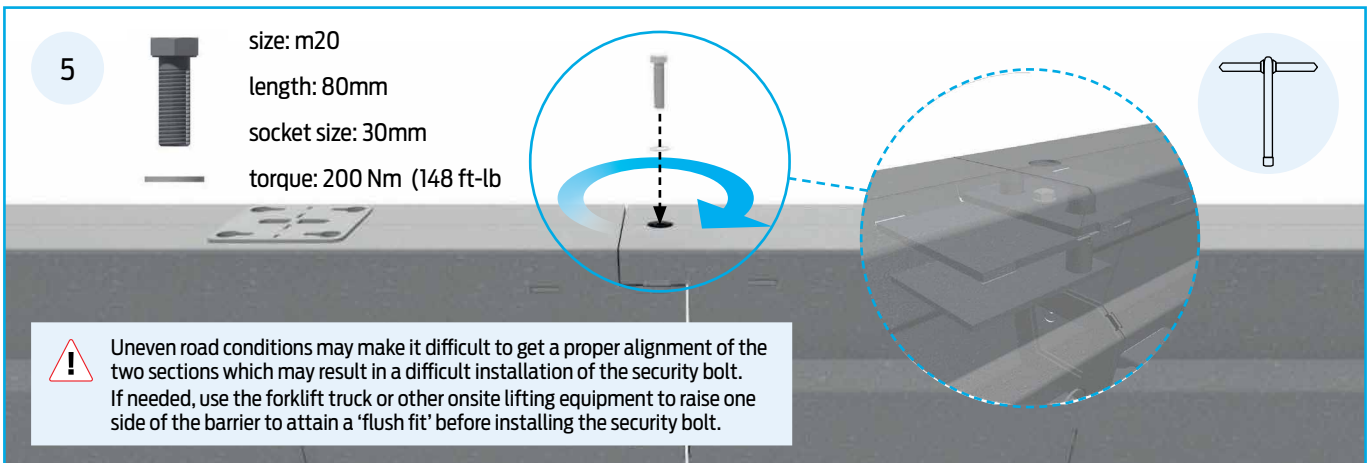

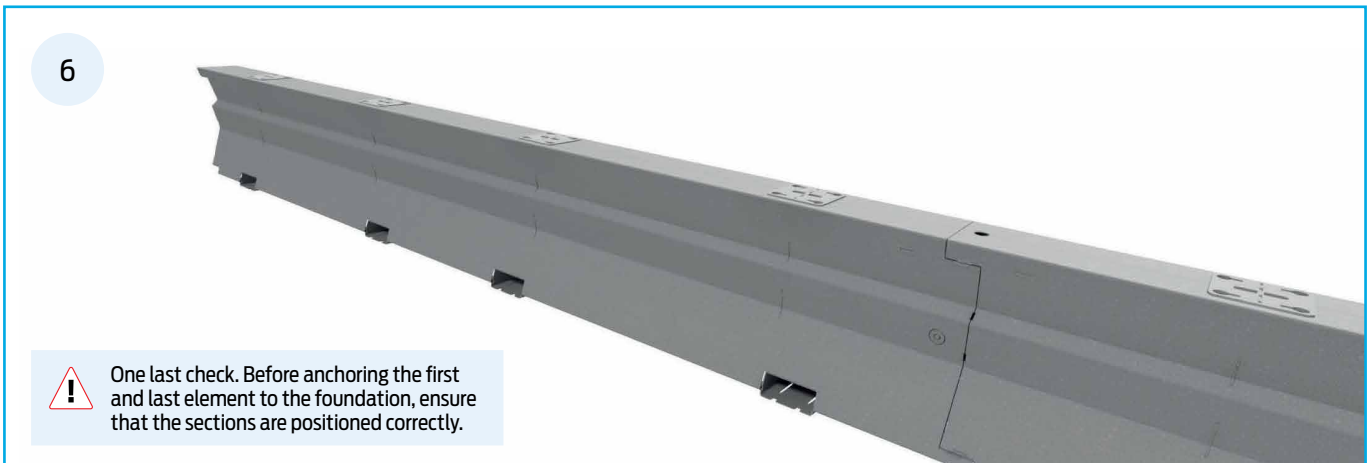

8.6. Finishing alignment of SafeZone and start anchoring first element

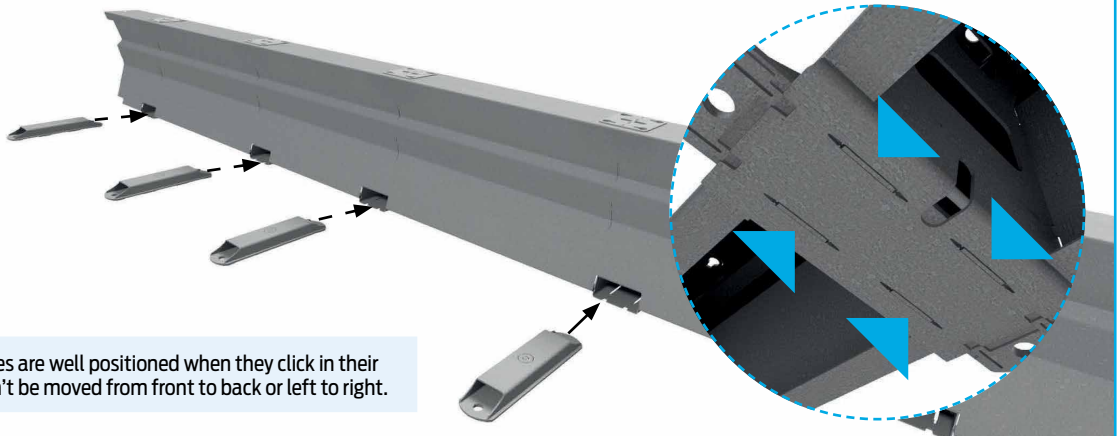

8.7. Insert the anchor plates (AS31840020)

7



 The anchor plates are well positioned when they click in their position and can't be moved from front to back or left to right.

8.8. Marking the drilling location (left and right side)

8

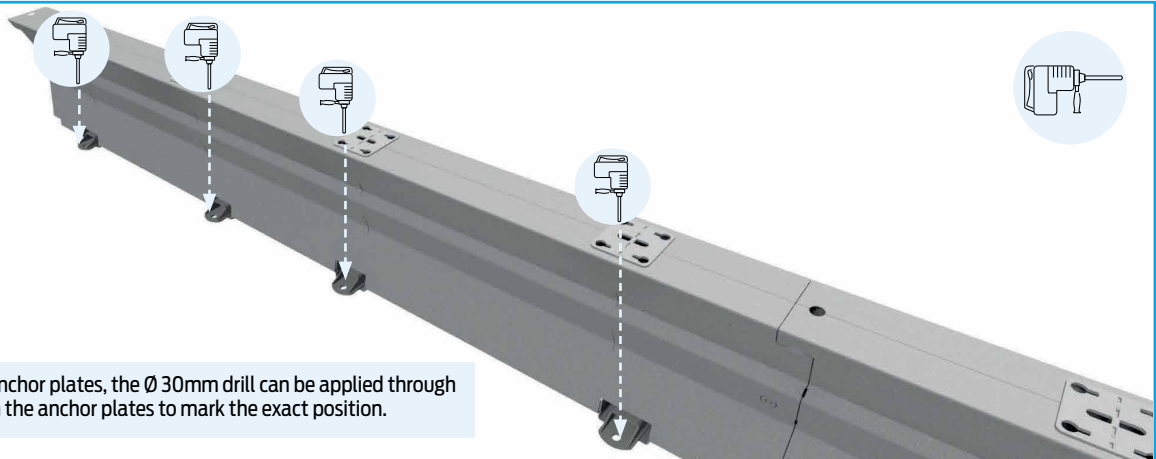

After placing the anchor plates, the \varnothing 30mm drill can be applied through the anchor holes in the anchor plates to mark the exact position.

8.9. Drilling the holes (left and right side)

9

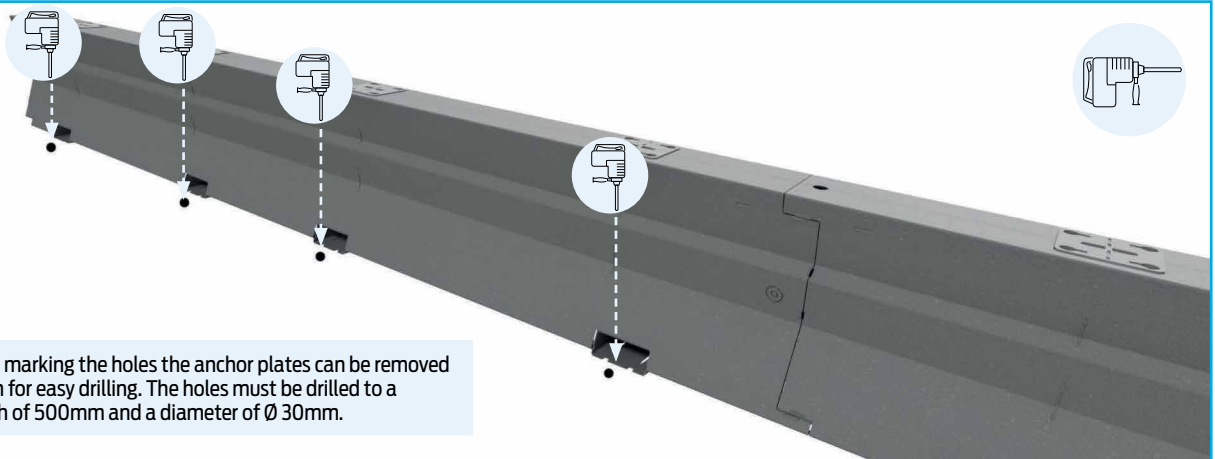

 After marking the holes the anchor plates can be removed again for easy drilling. The holes must be drilled to a depth of 500mm and a diameter of \varnothing 30mm.

8.10. Clean the drilled holes (left and right side)

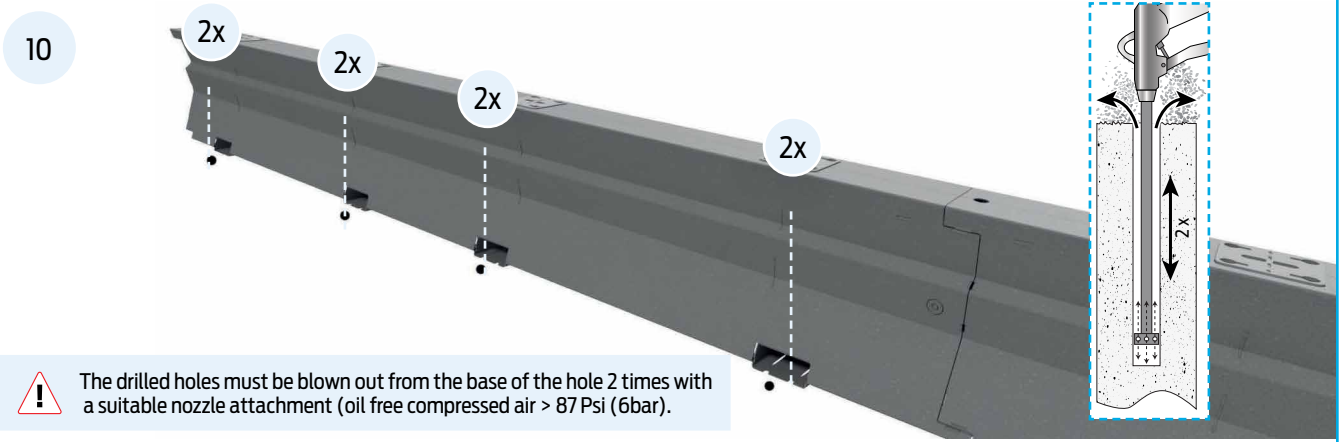

8.11. Placing anchor plates

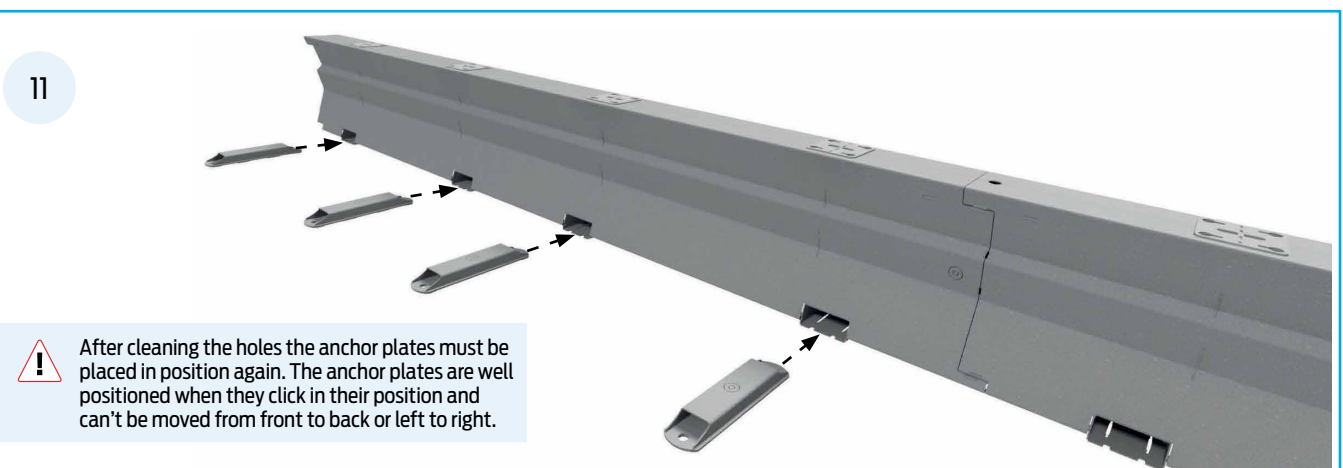

8.12. Insert pins (AS31642592)

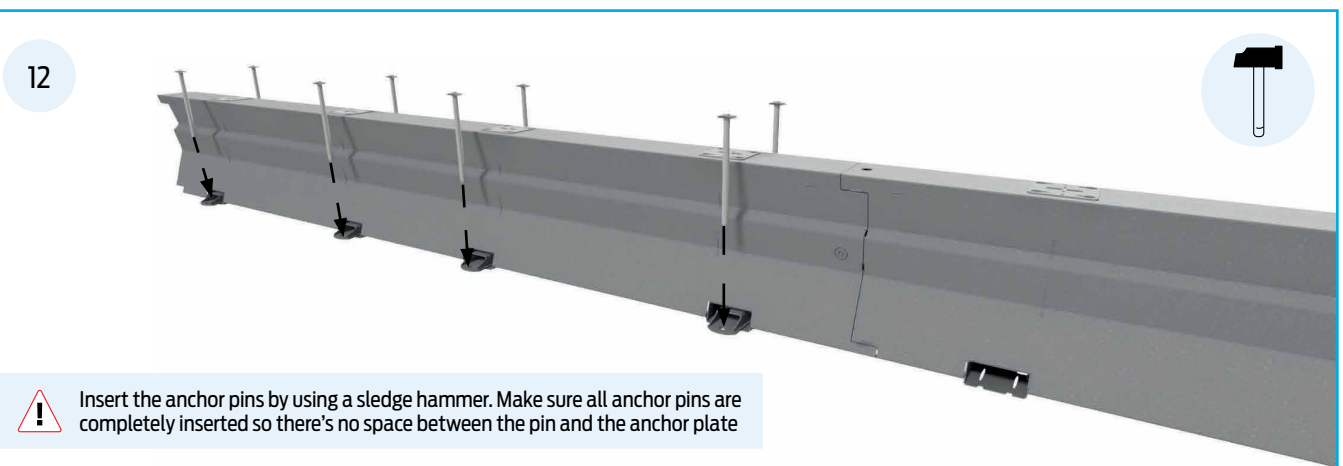

8.13. Finished first element

13



 After complete anchoring of the first element move to the last element.

8.14. Anchor the last element as well

14

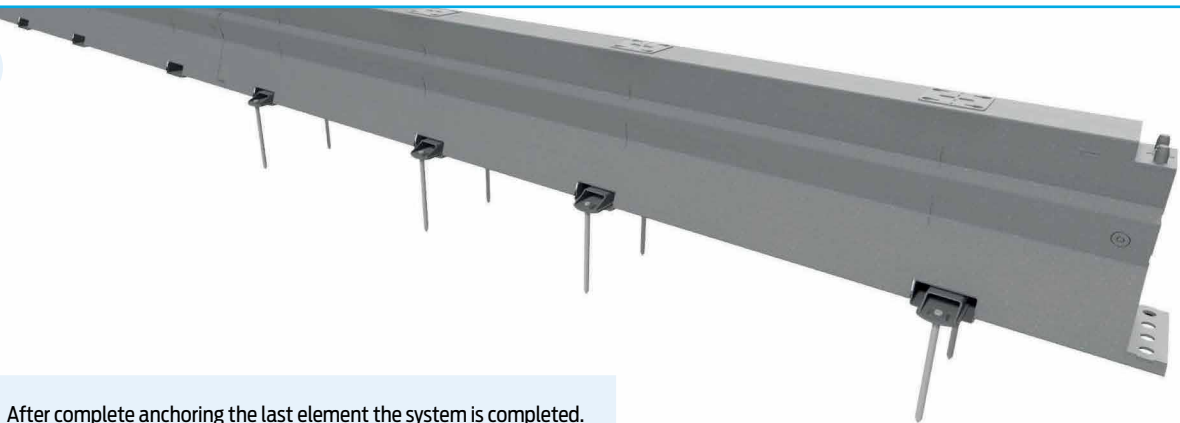

 After complete anchoring the last element the system is completed.

8.15. Completed SafeZone system

15

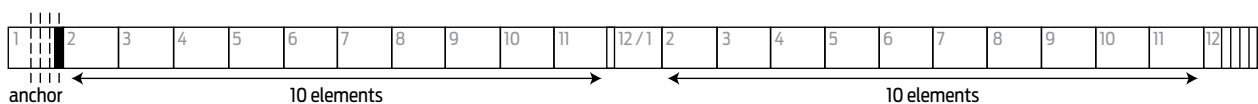

 The standard installation requires 4 anchors at the first and last element and 1 anchor every 69.6meter. Make sure there are always 10 unanchored elements in between. Use the second or third opening of the element for anchoring.

9. SafeZone Limited Deflection System

9.1. General

The SafeZone Limited Deflection System is a specially configured system with a decreased anchor distance, this system offers a very low working width. The SafeZone LDS configuration increases the usable workspace in which to carry out construction and maintenance work and still perform to a high containment level. It is particularly beneficial to contractors working on tight construction sites to allow maximum working space together with full safety guideline compliance.

9.2. Installation

A length of SafeZone Limited Deflection System is built up by standard Units of SafeZone with anchor plates every 11.6m.

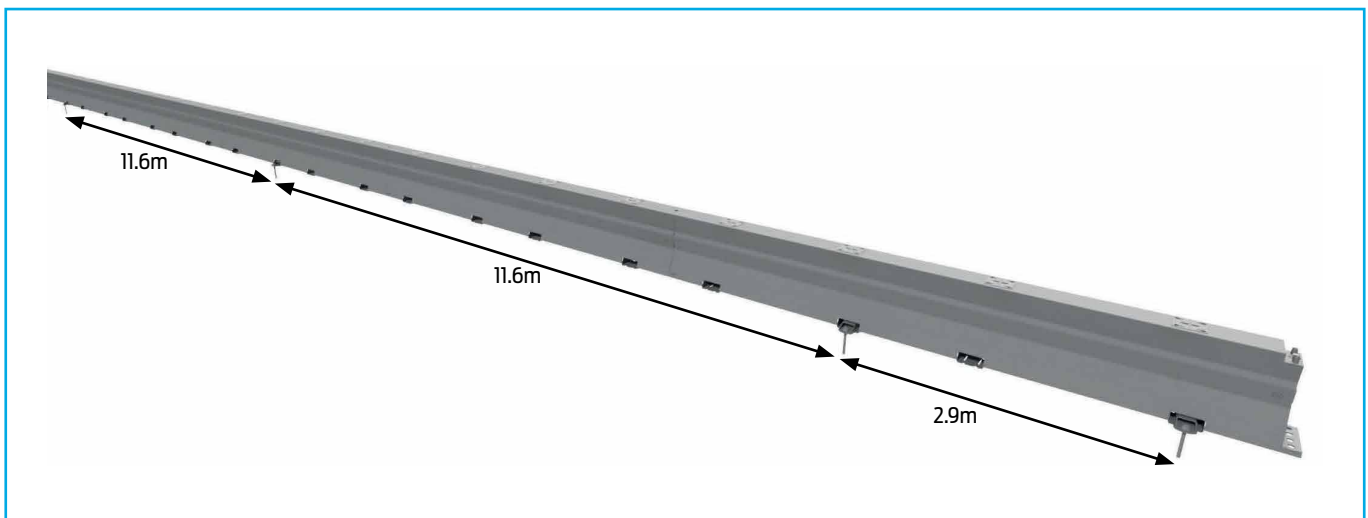

3 Rules for Anchoring:

1. Start with 2 anchor shoes / 4 anchors.
2. Install 1 anchor shoe / 2 anchors at 11.6m (38') center to center.
3. Install 2 anchor shoes /4 anchors in the last element of the string at the location of the 2nd and 4th opening as per image above.

10. Anchoring options on asphalt and concrete for Limited Deflection System

10.1. Foundation Type

Suitable foundation type for Limited Deflection System:

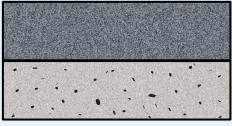
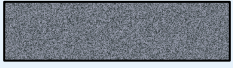
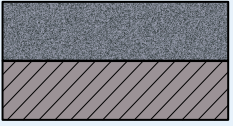

Foundation Type	Concrete Pad	Asphalt over subbase	Asphalt only	Asphalt over concrete
				
Anchor shoe type	1	1	1	1
Anchor pin type	C	B	B	B

Note: in case of concrete decks thinner than 300mm please consult manufacturer for advice.

10.2. Choice of anchoring

Type 1	Anchor shoe standard (AS31840020)	
--------	-----------------------------------	---

10.3. Anchor Pin

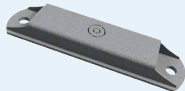
Anchor Pin Type		Diameter Drilled Hole	Anchor Shoe Type	Traffic Side	Non Traffic Side
Type B Threaded Rod Ø 30mm Length: 300mm	 (KE31840030)	Ø35mm 250mm depth	Type 1 	✓	✓
Type C Threaded Rod Ø 30mm Length: 175mm	 (KE31840031)	Ø35mm 125mm depth	Type 1 	✓	✓

11. SafeZone Limited Deflection System installation using pin type B

11.1. Start with standard SafeZone barrier section (AS150145-0421)

1

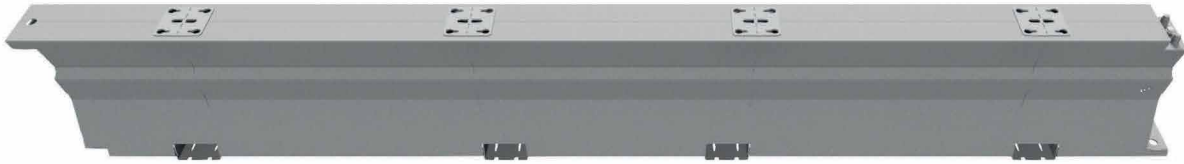



(AS31840000)

SafeZone Limited Deflection System is a standard installation of SafeZone with anchor plates positioned every 11.6m. The minimum installation length of SafeZone Limited Deflection System is 69.63 m.

11.2. Beginning of first string of barriers

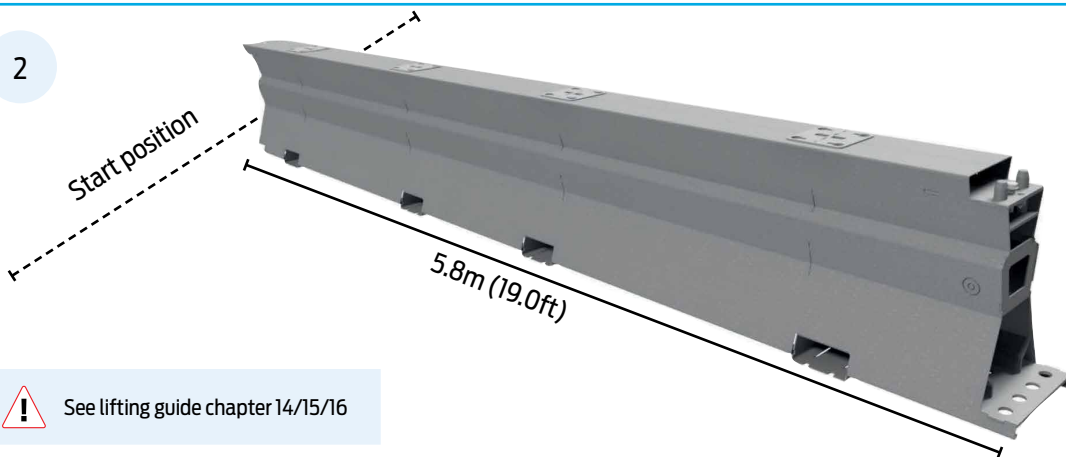
2



 See lifting guide chapter 14/15/16

11.3. The male coupling including the security bolt must face down stream

3

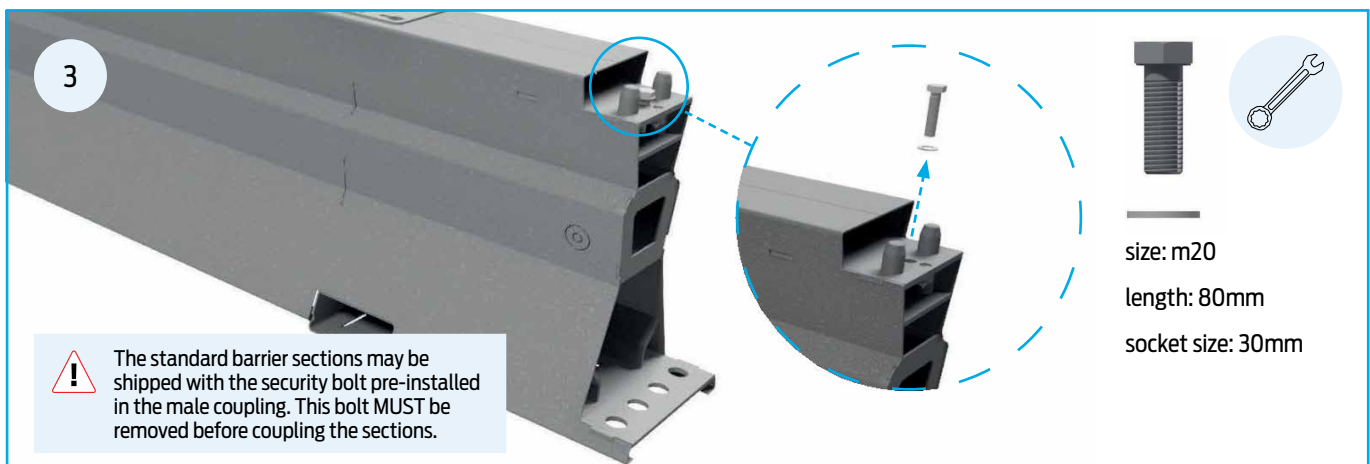

 The standard barrier sections may be shipped with the security bolt pre-installed in the male coupling. This bolt **MUST** be removed before coupling the sections.

11.4. Lower one element over the other

4



11.5. Lock the sections together with the security bolt using the ratchet or T-wrench

5



size: m20
length: 80mm
socket size: 30mm
torque: 200 Nm (148 ft-lb)

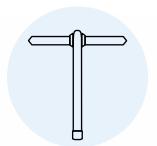
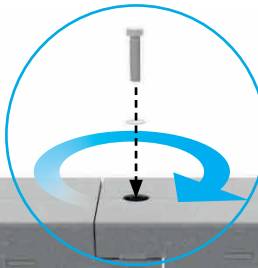

Uneven road conditions may make it difficult to get a proper alignment of the two sections which may result in a difficult installation of the security bolt. If needed, use the forklift truck or other onsite lifting equipment to raise one side of the barrier to attain a 'flush fit' before installing the security bolt.

11.6. Finishing alignment of SafeZone and start anchoring first and last element

6



One last check. Before anchoring the first and last element to the foundation, ensure that the sections are positioned correctly.

11.7. Insert the anchor plates (AS31840020)

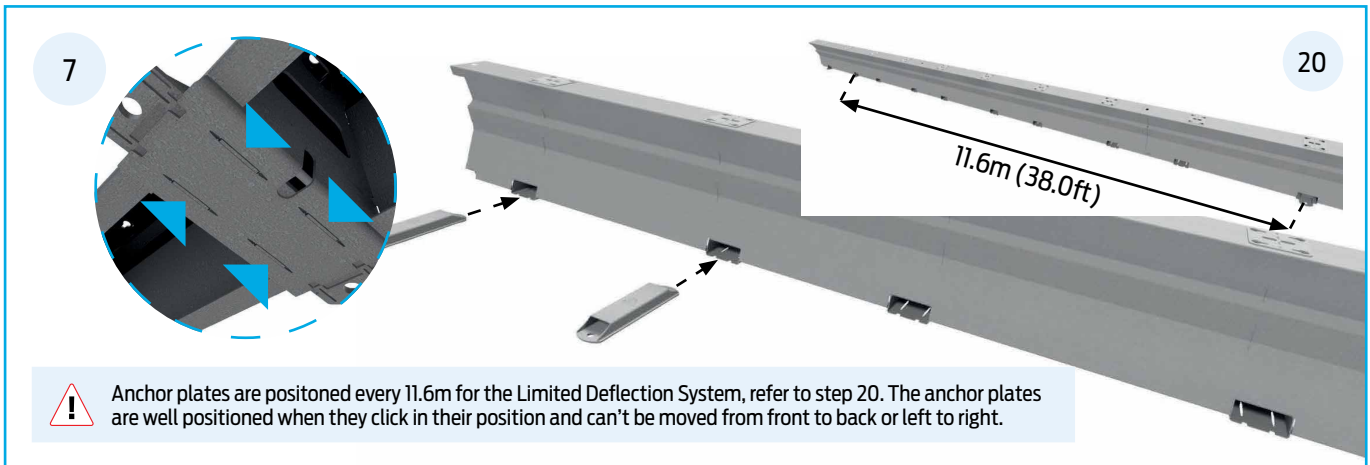

11.8. Marking the drilling location

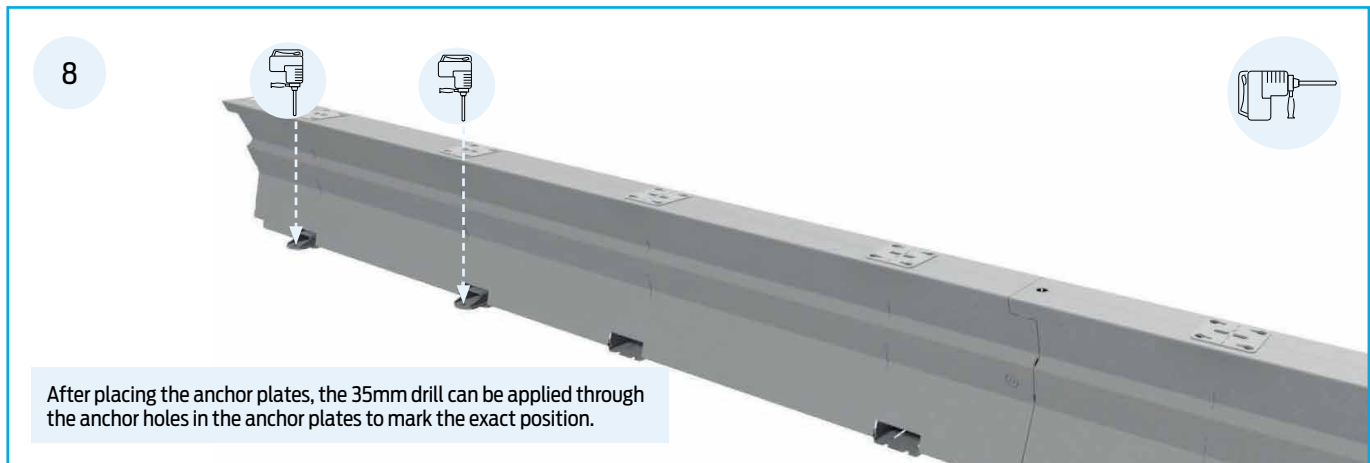

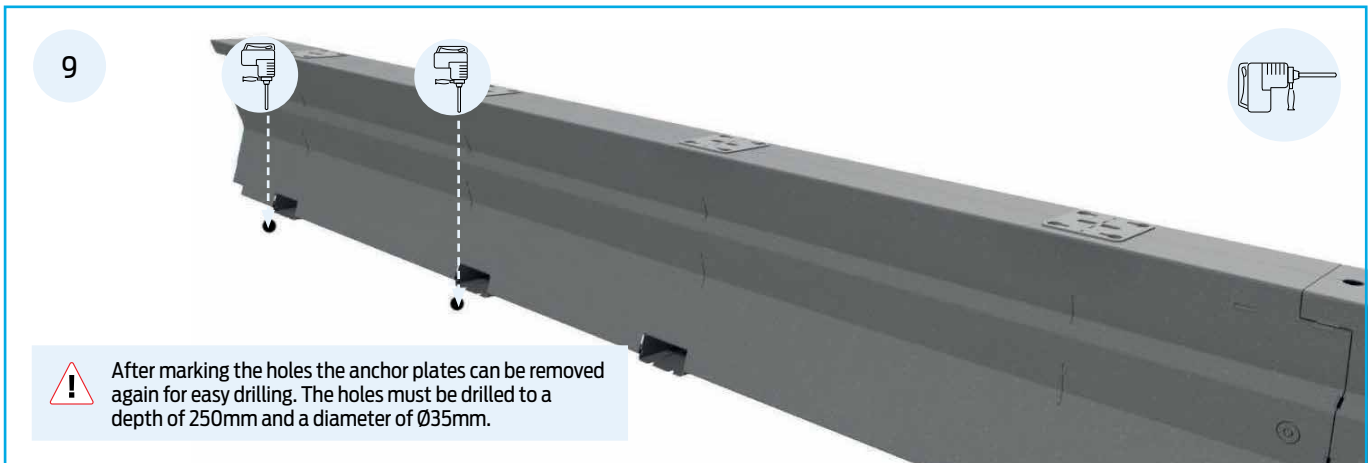

11.9. Drilling the holes

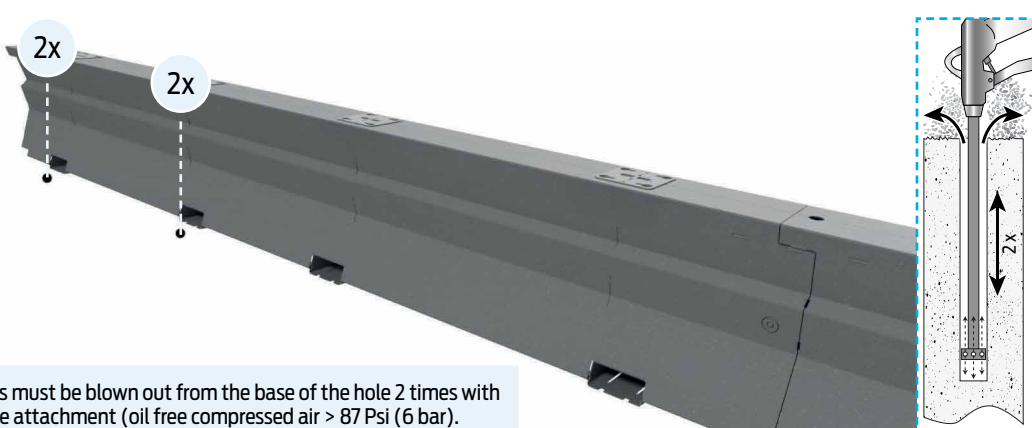

11.10. Clean the drilled holes to ensure a good adhesion of the chemical mortar to the asphalt

10



 The drilled holes must be blown out from the base of the hole 2 times with a suitable nozzle attachment (oil free compressed air > 87 Psi (6 bar)).

11.11. Brush the drilled hole twice with a special steel brush FIS BS Ø35mm in combination with a power tool

11



 Brush the drilled holes twice.

11.12. Blow out the drilled hole twice again

12

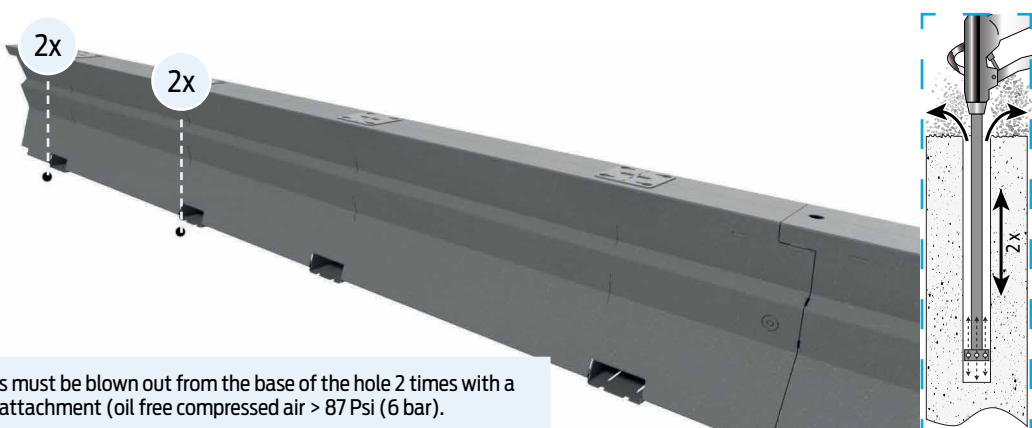

 The drilled holes must be blown out from the base of the hole 2 times with a suitable nozzle attachment (oil free compressed air > 87 Psi (6 bar)).

11.13. Placing anchor plates

13

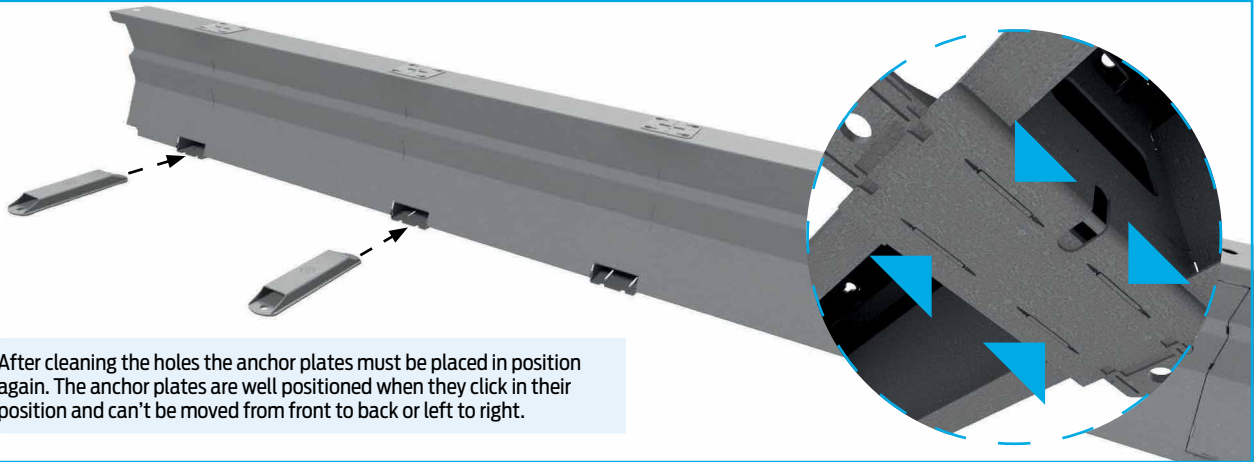

! After cleaning the holes the anchor plates must be placed in position again. The anchor plates are well positioned when they click in their position and can't be moved from front to back or left to right.

11.14. Measure the ground (hole) temperature

14

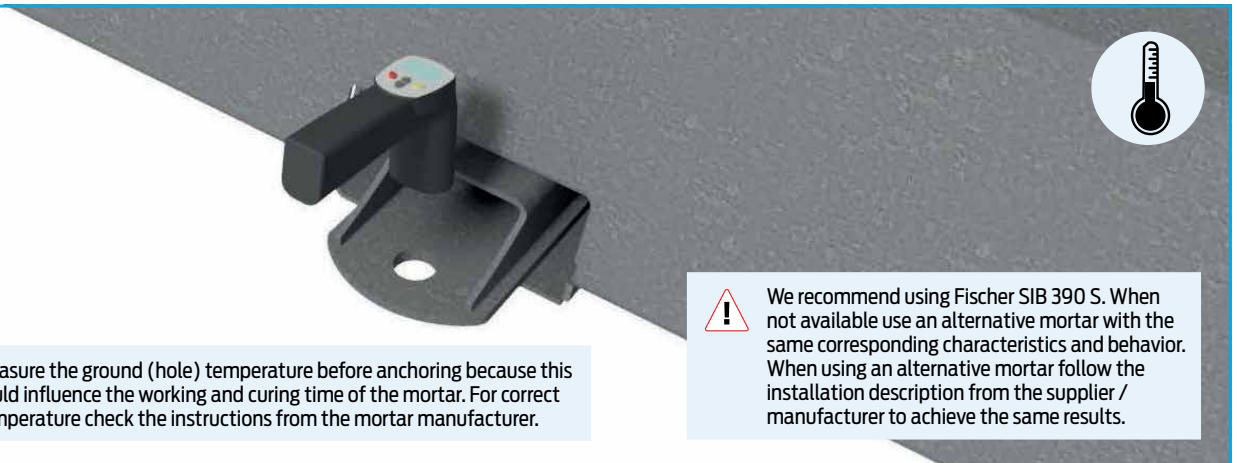

! Measure the ground (hole) temperature before anchoring because this could influence the working and curing time of the mortar. For correct temperature check the instructions from the mortar manufacturer.

! We recommend using Fischer SIB 390 S. When not available use an alternative mortar with the same corresponding characteristics and behavior. When using an alternative mortar follow the installation description from the supplier / manufacturer to achieve the same results.

11.15. Prepare mortar cartridge

15



- !**
1. Remove the cap from the cartridge by turning and pulling it off.
 2. Attach the static mixer, tighten it firmly and lock it in place (turn to right).
 3. Place the cartridge in the dispenser.
 4. Press approx. 10cm of material out until there is mortar coming out in an even grey color. Mortar which is not grey color will not cure and must be disposed of.

! We recommend using Fischer SIB 390 S. When not available use an alternative mortar with the same corresponding characteristics and behavior. When using an alternative mortar follow the installation description from the supplier / manufacturer to achieve the same results.

11.16. Fill the hole with injection mortar

16



Fill the drill hole with injection mortar starting at the bottom, make sure that it does not contain any air bubbles, +/- 110ml per anchor hole.

11.17. Insert threaded rod (KE31840030)

17



Anchoring pin must be straight and free of oil and other contaminants. Mark the anchor with correct embedment depth 250mm. Press the anchor pin down to the bottom of the hole, turning its lightly while pressing. After inserting the pin, excess mortar must emerge from the mouth of the hole. If no mortar appears at the surface of the hole, the anchoring pin must be removed immediately and mortar must be injected again. Do not disturb the anchoring element until cure time has elapsed.

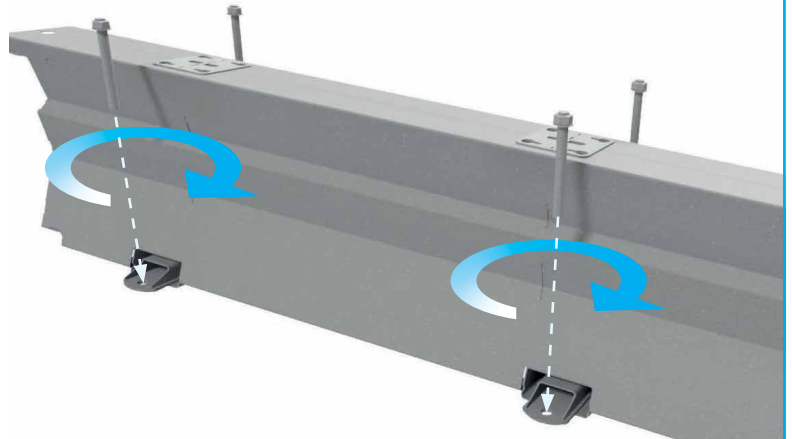

11.18. Tighten nut after mortar has hardened

18



Torque the M30 hex nuts including flat washer on the anchor studs after curing time has elapsed, torque to appr. 106Nm (78ft-lb) for asphalt and 300Nm (220ft-lb) for concrete.

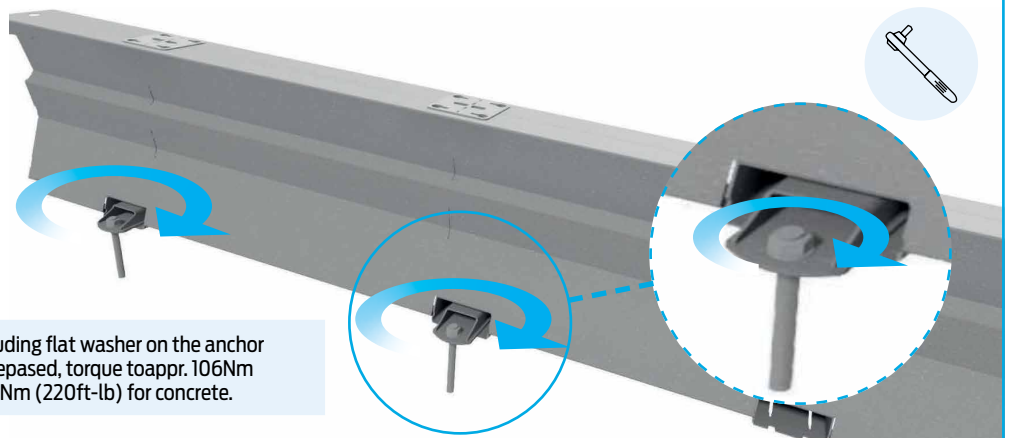

11.19. Remember to anchor the last element as well

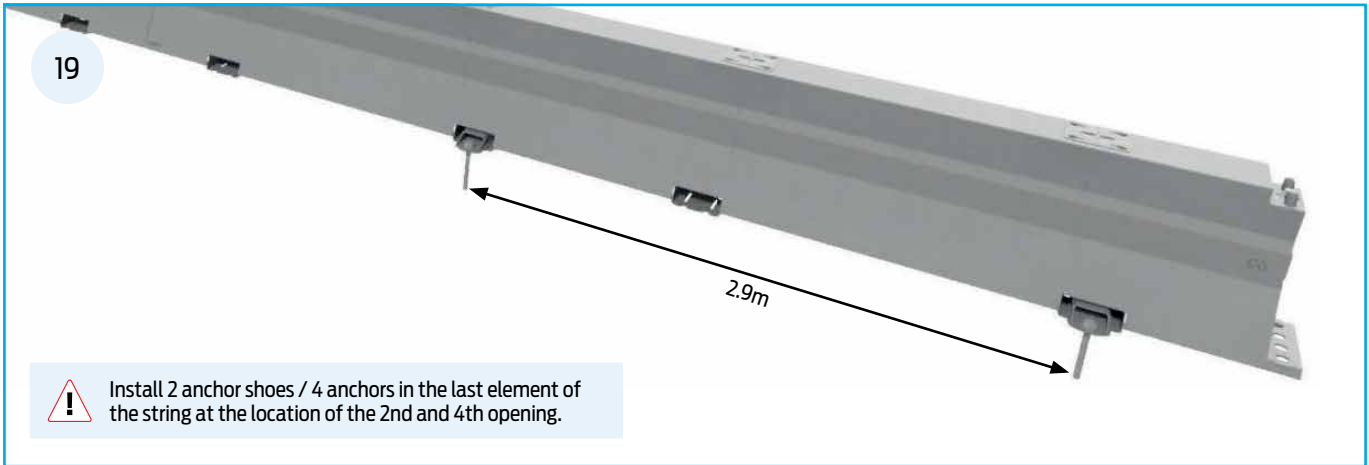

11.20. A length of SafeZone Limited Deflection System is built up with anchor plates every 11.6m

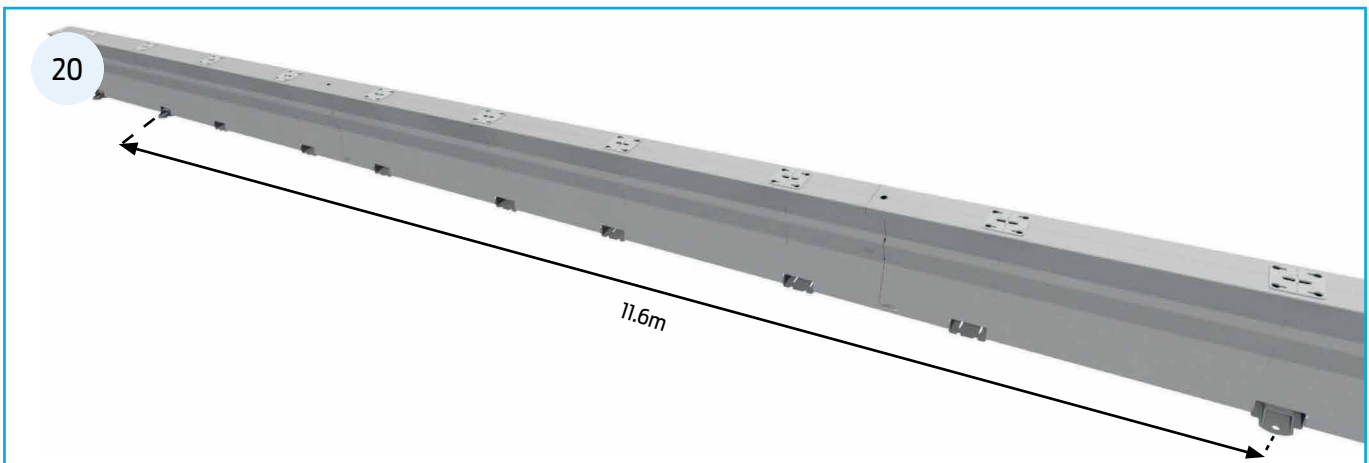

11.21. Completed SafeZone Limited Deflection System

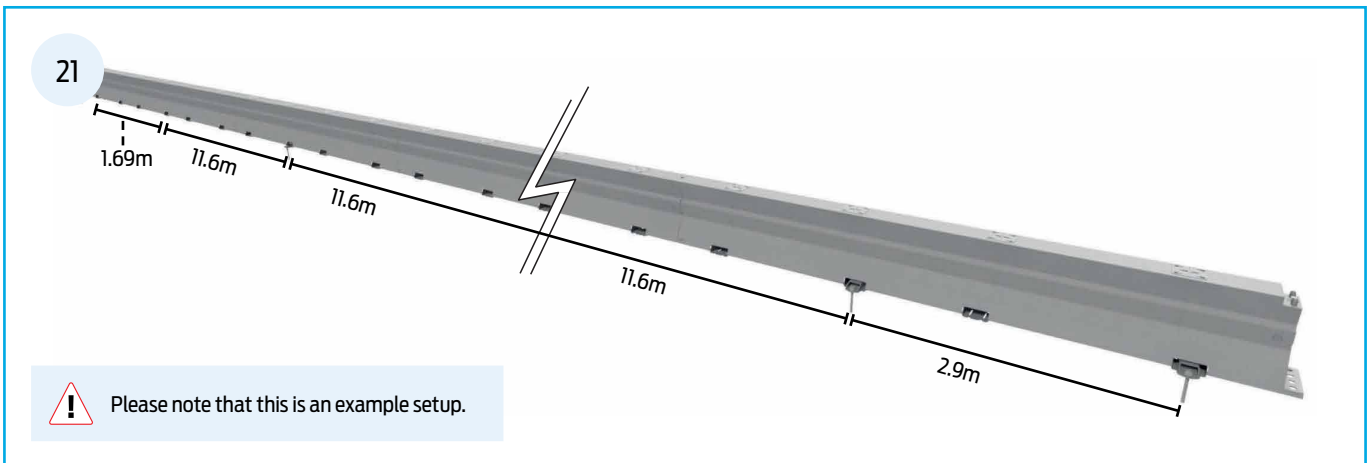

12. SafeZone Minimum Deflection System

12.1. General

The SafeZone Minimum Deflection System is a specially configured system with a decreased anchor distance, this system offers a very low working width. The SafeZone MDS configuration increases the usable workspace in which to carry out construction and maintenance work and still perform to a high containment level. It is particularly beneficial to contractors working on tight construction sites to allow maximum working space together with full safety guideline compliance.

12.2. Installation

A length of SafeZone Minimum Deflection System is built up by standard Units of SafeZone with anchor plates every 5.8m.

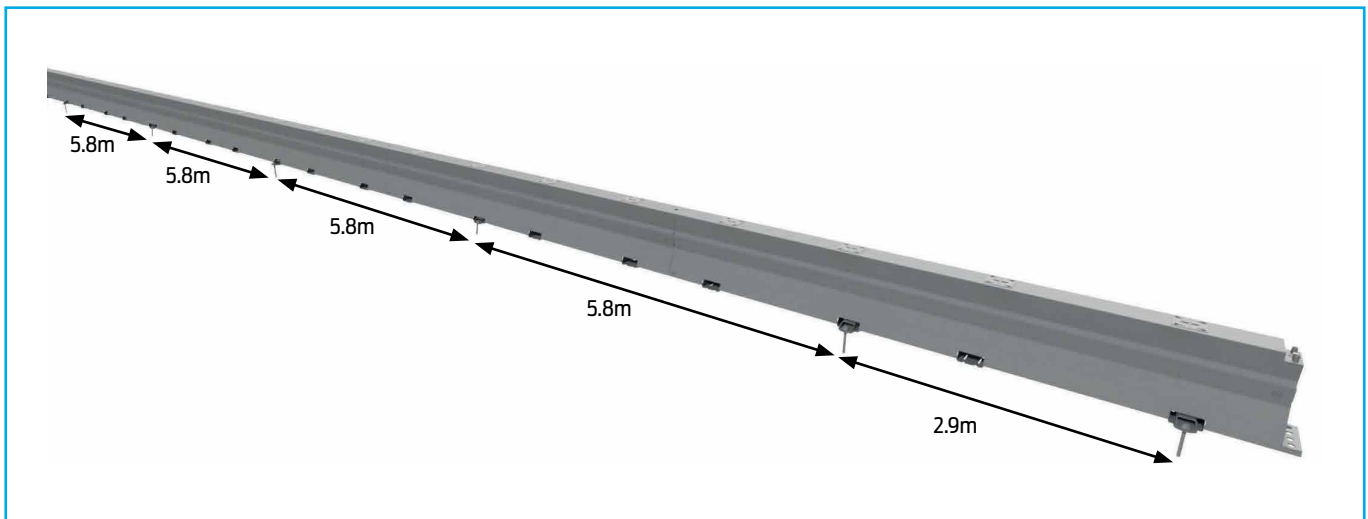

3 Rules for Anchoring:

1. Start with 2 anchor shoes / 4 anchors.
2. Install 1 anchor shoe / 2 anchors at 5.8m (19') center to center.
3. Install 2 anchor shoes / 4 anchors in the last element of the string at the location of the 2nd and 4th opening as per image above.

13. Anchoring options on asphalt and concrete for Minimum Deflection System

13.1. Foundation Type

Suitable foundation type for Minimum Deflection System:

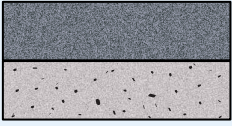
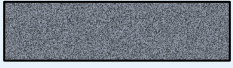
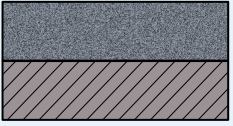

Foundation Type	Concrete Pad	Asphalt over subbase	Asphalt only	Asphalt over concrete
				
Anchor shoe type	1	1	1	1
Anchor pin type	B	B	B	B

Note: in case of concrete decks thinner than 300mm please consult manufacturer for advice.

13.2. Choice of anchoring

Type 1	Anchor shoe standard (AS31840020)	
--------	-----------------------------------	---

13.3. Anchor Pin

Anchor Pin Type		Diameter Drilled Hole	Anchor Shoe Type	Traffic Side	Non Traffic Side
Type B Threaded Rod Ø 30mm Length: 300mm		(KE31840030) Ø35mm 250mm depth	Type 1 	✓	✓

14. SafeZone Minimum Deflection System installation using pin type B

14.1. Start with standard SafeZone barrier section (AS150145-0421)

1

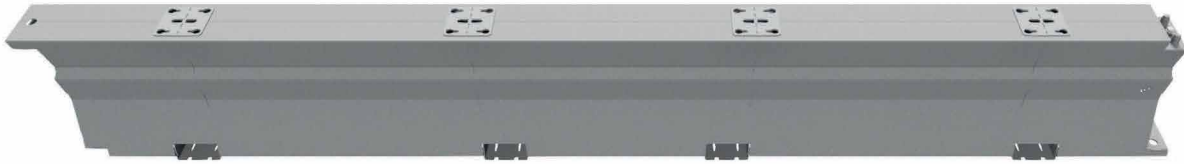



(AS31840000)

SafeZone Limited Deflection System is a standard installation of SafeZone with anchor plates positioned every 11.6m. The minimum installation length of SafeZone Limited Deflection System is 69.63 m.

14.2. Beginning of first string of barriers

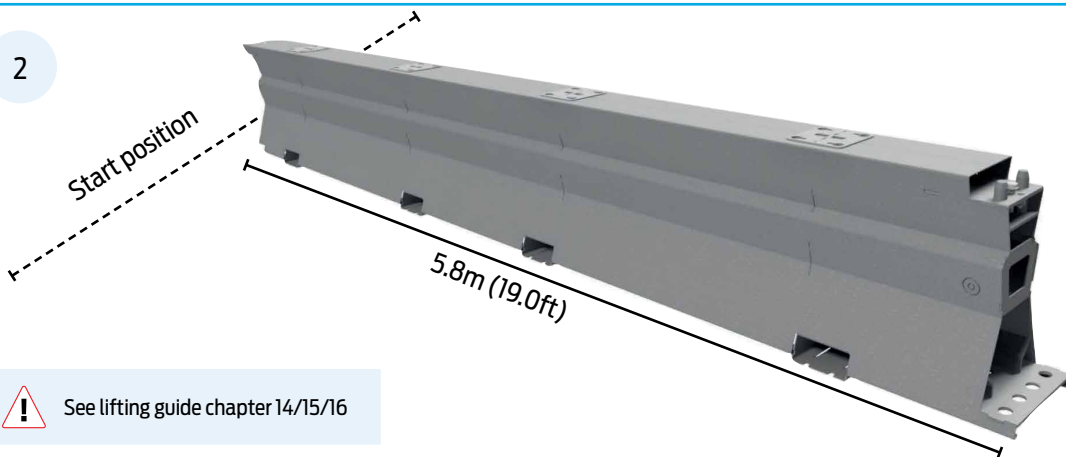
2



 See lifting guide chapter 14/15/16

14.3. The male coupling including the security bolt must face down stream

3

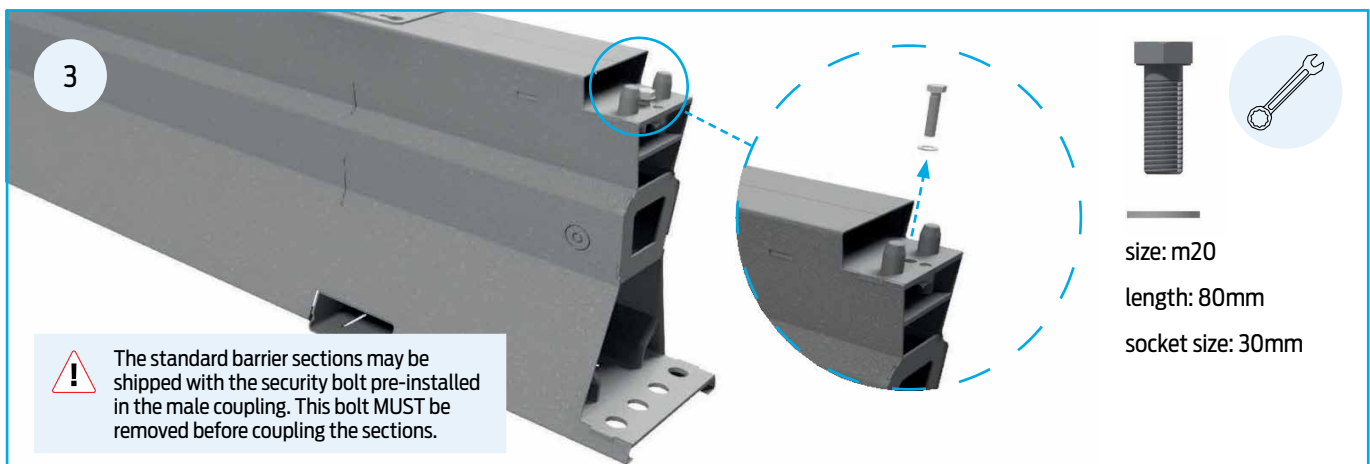

 The standard barrier sections may be shipped with the security bolt pre-installed in the male coupling. This bolt **MUST** be removed before coupling the sections.

14.4. Lower one element over the other

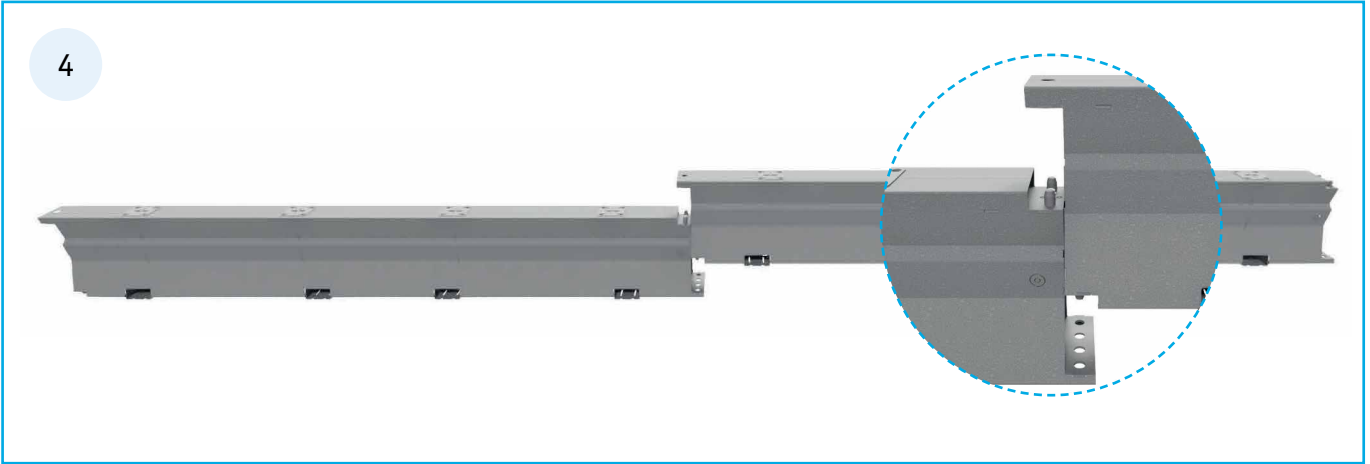

14.5. Lock the sections together with the security bolt using the ratchet or T-wrench

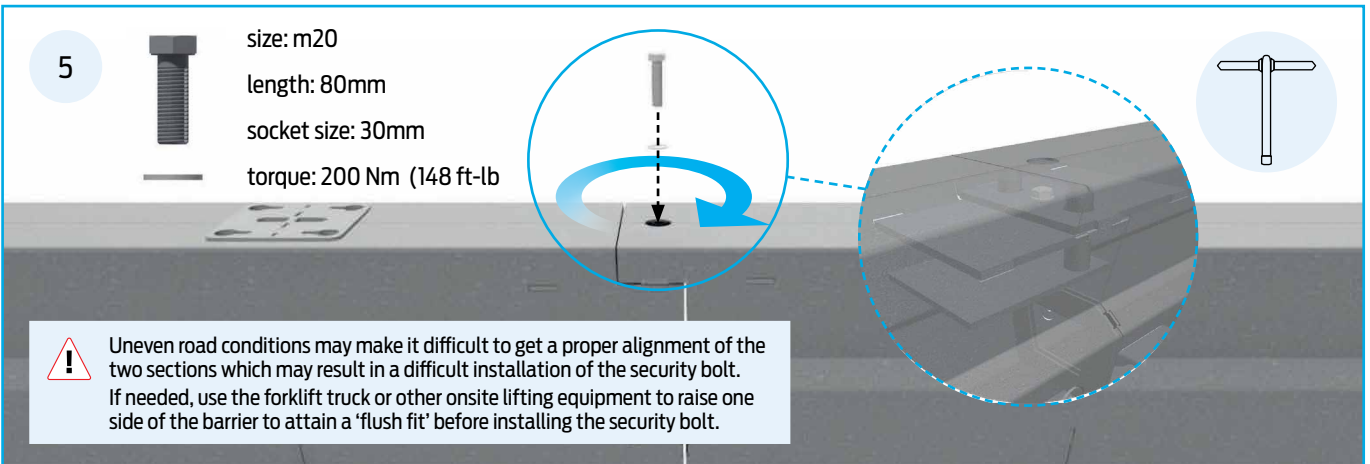

14.6. Finishing alignment of SafeZone and start anchoring first and last element

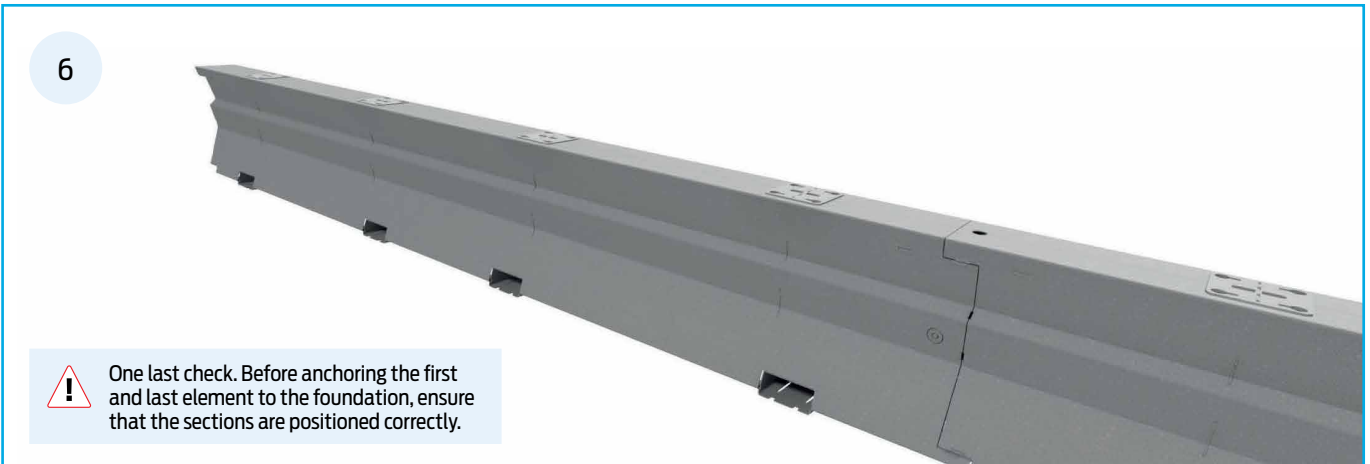

14.7. Insert the anchor plates (AS31840020)

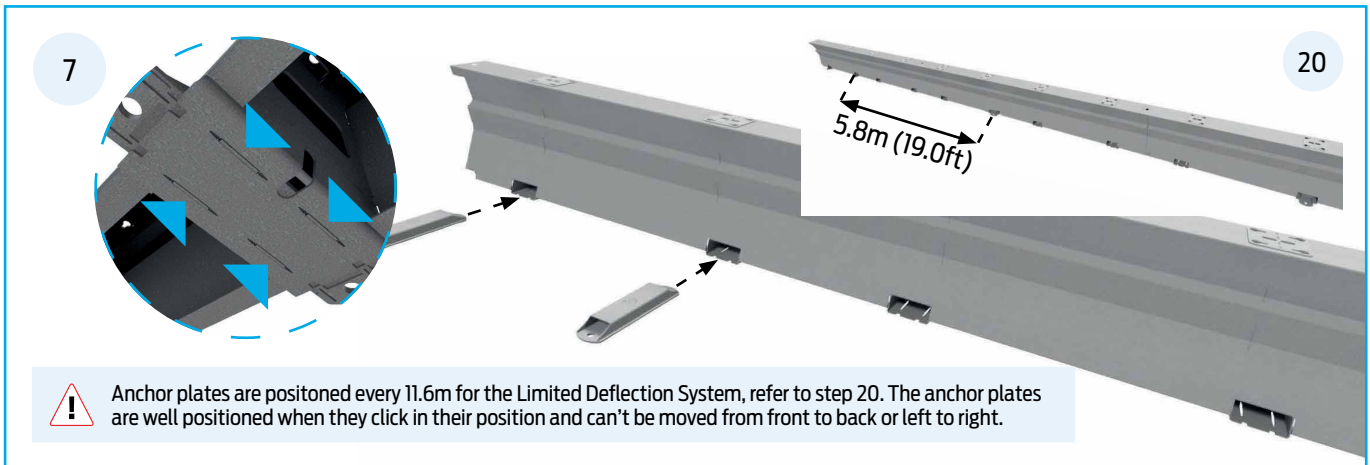

14.8. Marking the drilling location

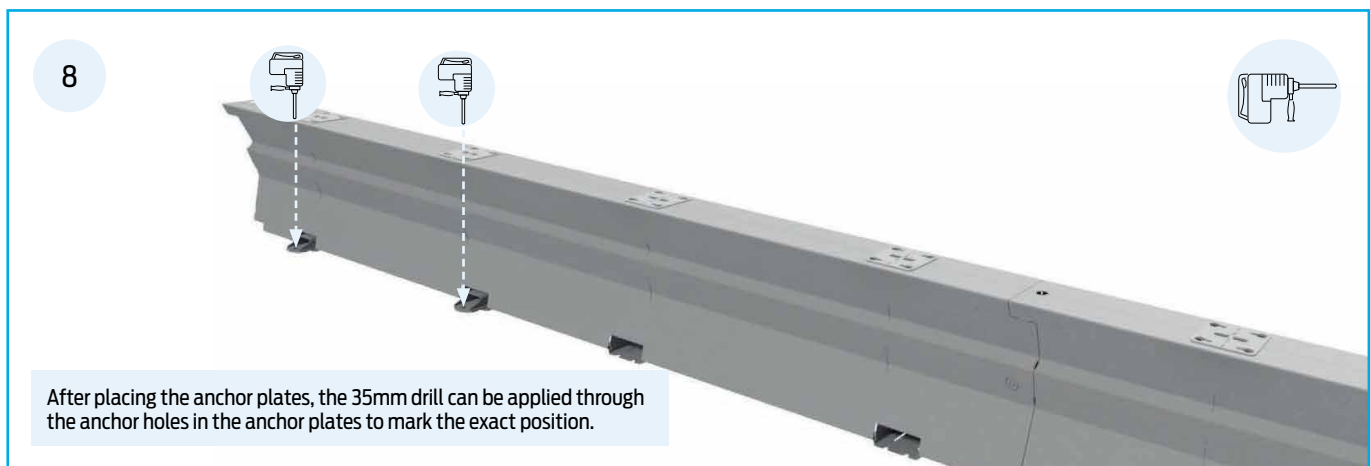

14.9. Drilling the holes

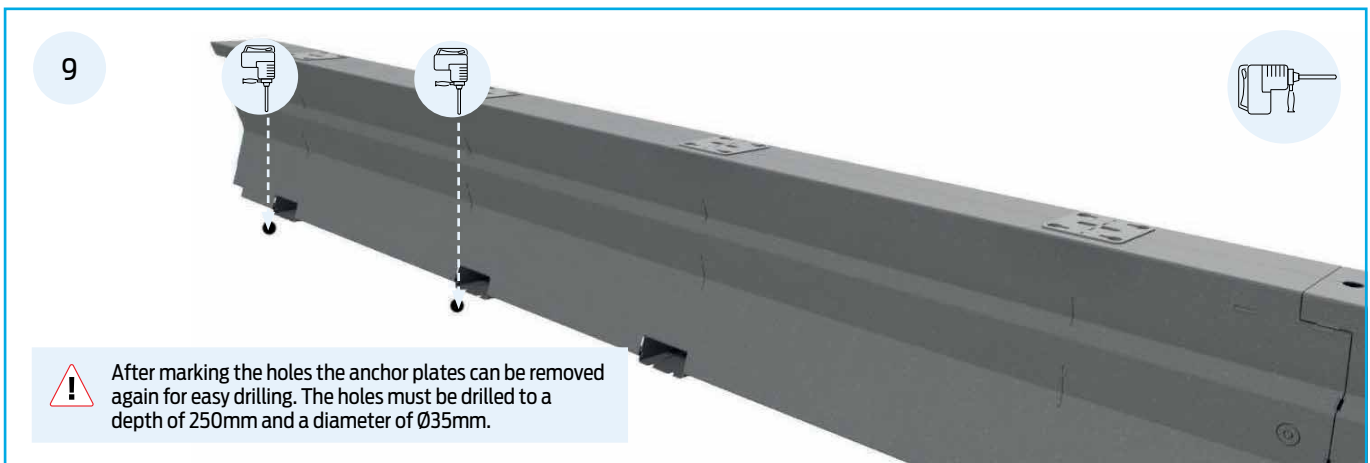



14.10. Clean the drilled holes to ensure a good adhesion of the chemical mortar to the asphalt

10

2x

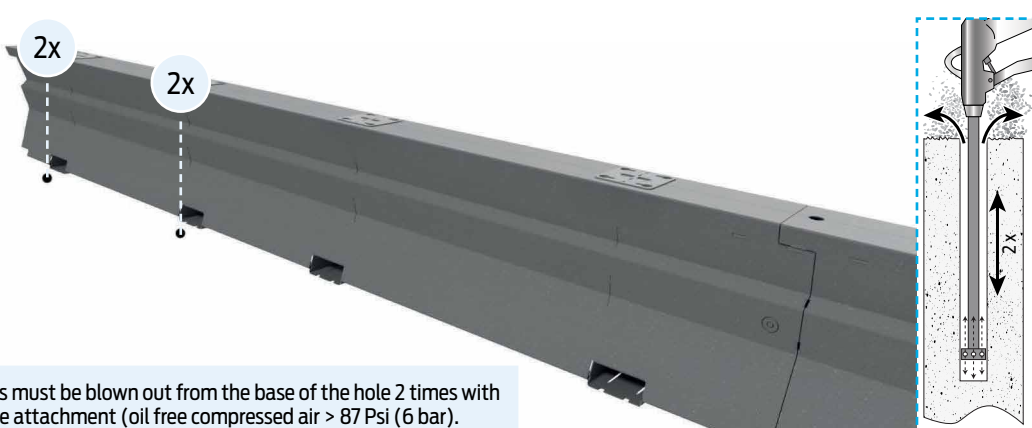
2x



 The drilled holes must be blown out from the base of the hole 2 times with a suitable nozzle attachment (oil free compressed air > 87 Psi (6 bar)).

14.11. Brush the drilled hole twice with a special steel brush FIS BS Ø35mm in combination with a power tool

11

2x

2x



 Brush the drilled holes twice.

14.12. Blow out the drilled hole twice again

12

2x

2x

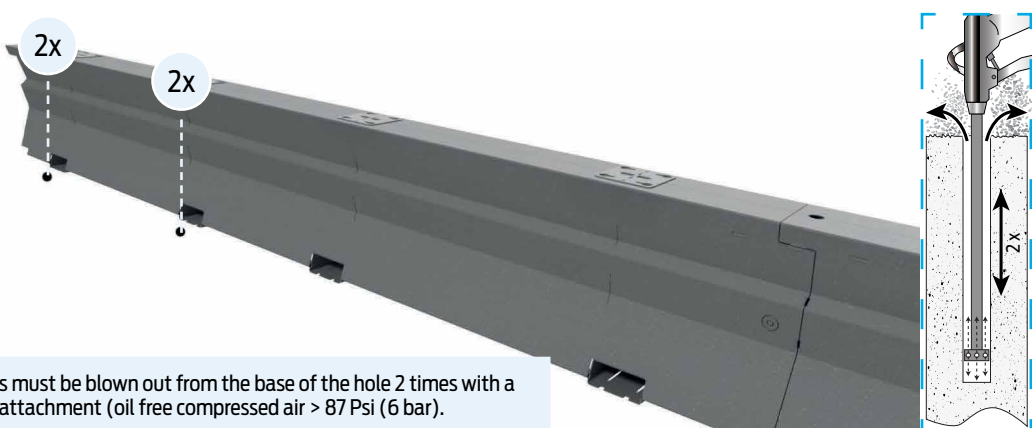

 The drilled holes must be blown out from the base of the hole 2 times with a suitable nozzle attachment (oil free compressed air > 87 Psi (6 bar)).

14.13. Placing anchor plates

13

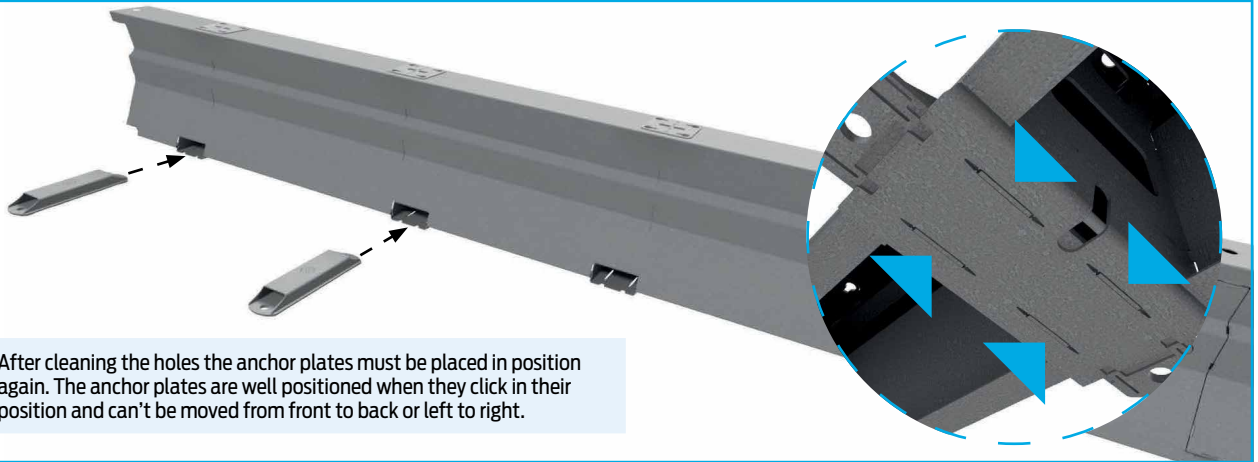

! After cleaning the holes the anchor plates must be placed in position again. The anchor plates are well positioned when they click in their position and can't be moved from front to back or left to right.

14.14. Measure the ground (hole) temperature

14

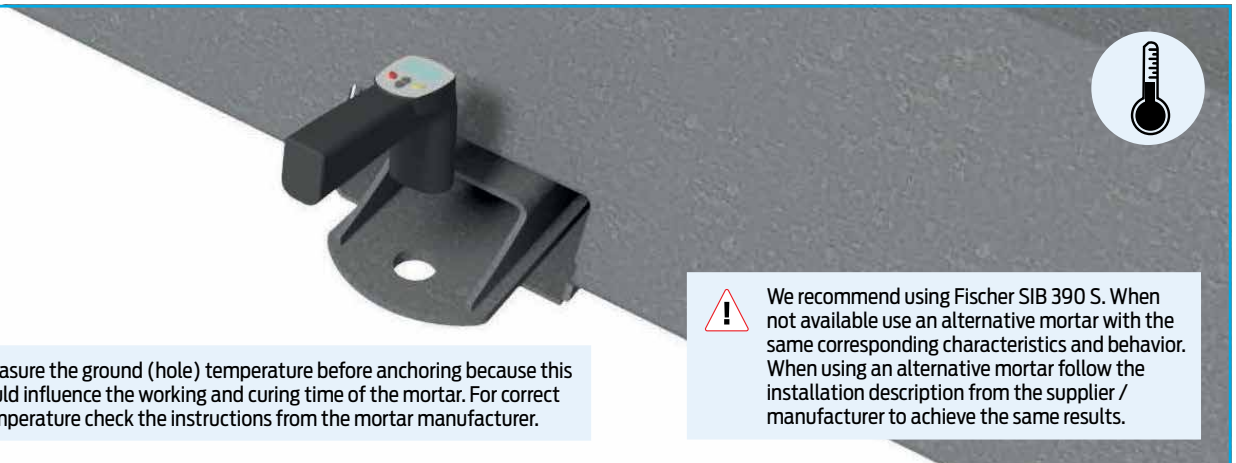

! Measure the ground (hole) temperature before anchoring because this could influence the working and curing time of the mortar. For correct temperature check the instructions from the mortar manufacturer.

! We recommend using Fischer SIB 390 S. When not available use an alternative mortar with the same corresponding characteristics and behavior. When using an alternative mortar follow the installation description from the supplier / manufacturer to achieve the same results.

14.15. Prepare mortar cartridge

15



- !**
1. Remove the cap from the cartridge by turning and pulling it off.
 2. Attach the static mixer, tighten it firmly and lock it in place (turn to right).
 3. Place the cartridge in the dispenser.
 4. Press approx. 10cm of material out until there is mortar coming out in evenly grey colour. Mortar which is not grey colour will not cure and must be disposed of.

! We recommend using Fischer SIB 390 S. When not available use an alternative mortar with the same corresponding characteristics and behavior. When using an alternative mortar follow the installation description from the supplier / manufacturer to achieve the same results.

14.16. Fill the hole with injection mortar

16



 Fill the drill hole with injection mortar starting at the bottom, make sure that it does not contain any air bubbles, +/- 110ml per anchor hole.

14.17. Insert threaded rod (KE31840030)

17



 Anchoring pin must be straight and free of oil and other contaminants. Mark the anchor with correct embedment depth 250mm. Press the anchor pin down to the bottom of the hole, turning its lightly while pressing. After inserting the pin, excess mortar must emerge from the mouth of the hole. If no mortar appears at the surface of the hole, the anchoring pin must be removed immediately and mortar must be injected again. Do not disturb the anchoring element until cure time has elapsed.

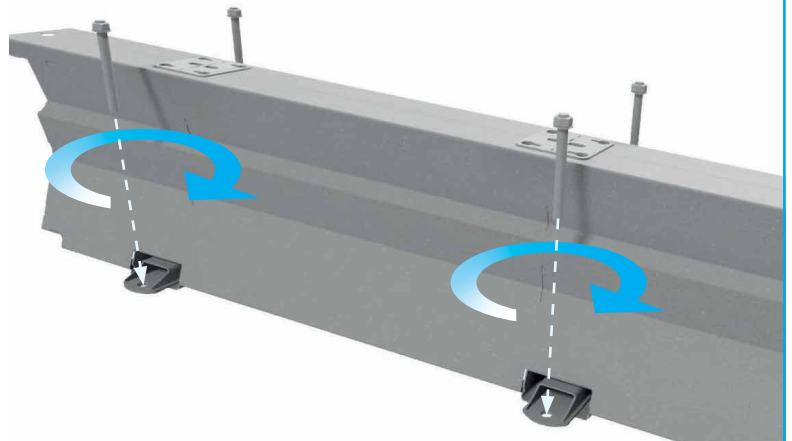

14.18. Tighten nut after mortar has hardened

18



 Torque the M30 hex nuts including flat washer on the anchor studs after curing time has elapsed, torque to appr. 106Nm (78ft-lb) for asphalt and 300Nm (220ft-lb) for concrete.

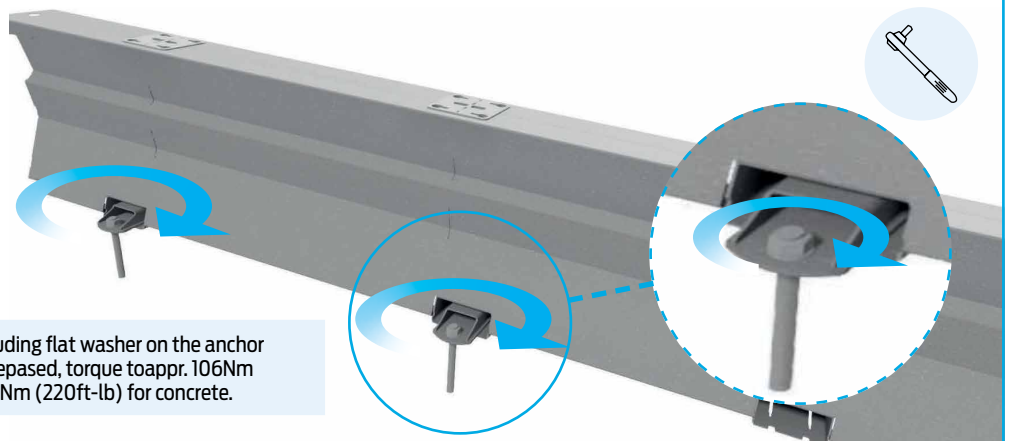

14.19. Remember to anchor the last element as well

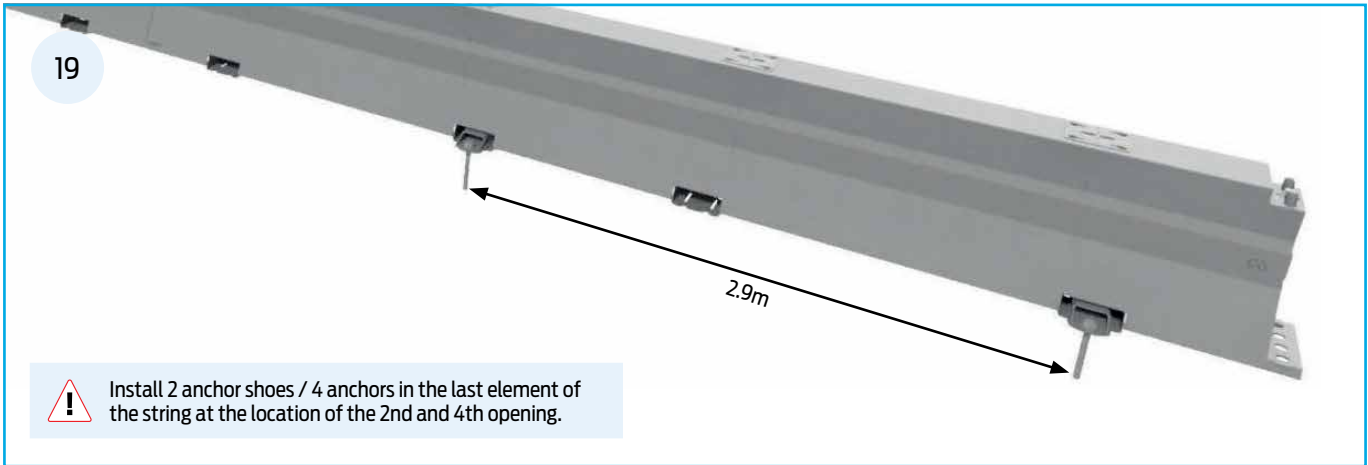

14.20. A length of SafeZone Minimum Deflection System is built up with anchor plates every 11.6m

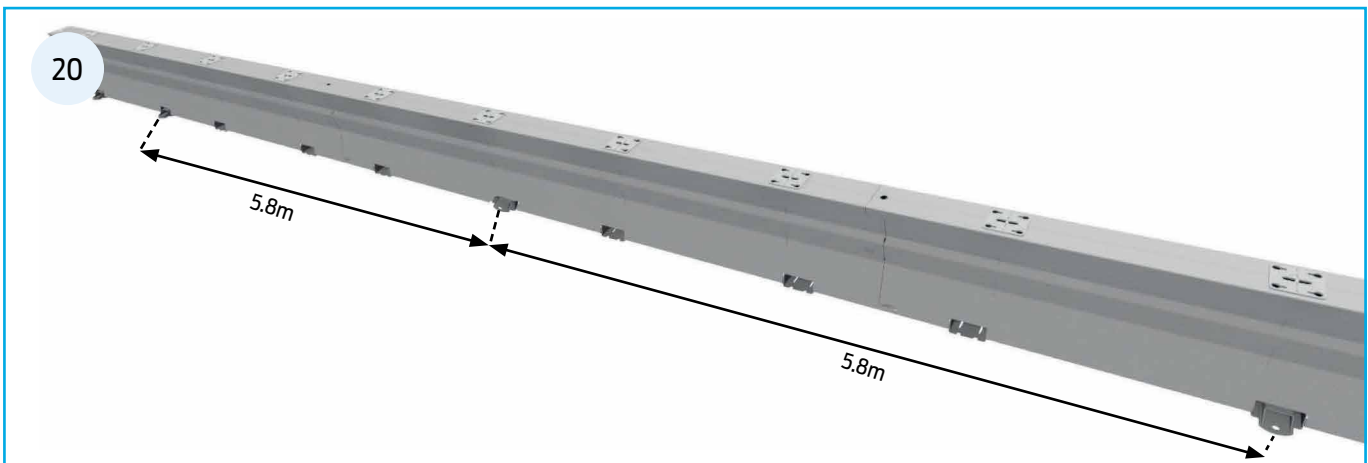

14.21. Completed SafeZone Minimum Deflection System

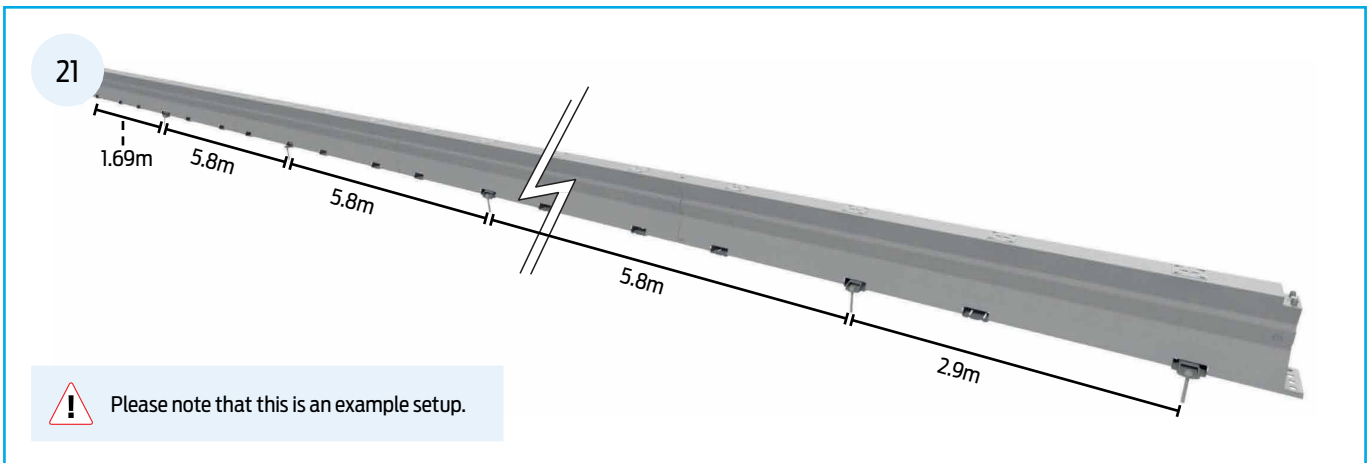

15. Maintenance and repair

SafeZone™ has an estimated 20-years life cycle. With years of experience with BarrierGuard 800 and through rigorous testing SafeZone sections have proven to be very robust and extremely hard wearing. We recommend some very basic maintenance schedules detailed below. SafeZone sections should be thoroughly inspected prior to dispatch to the job site, during the inspection make sure that all the fasteners are present, there is no sign of damage to the Quick Connect and that there is no creases or dents in the barrier that could prevent it connecting together during the installation. If any of the above faults are detected then the damaged section or sections of barrier should be marked and put to one side for further assessments to take place and repairs made before the section of SafeZone is used again.

SafeZone is predominantly used for road work situations. There is usually personnel driving through the site, and also as the barrier is usually only installed for medium or short term it can be regularly inspected as it is returned to storage and again inspected as it is dispatched to the next job site. The installer can determine a suitable detection interval in connection with accident rate and traffic flow on the relevant route.

The drive by inspection is usually achievable by driving fairly slowly along the length of the installed barrier, depending on the location and site conditions then this may require additional safety systems put in place for example traffic management. During this inspection checks should be made for any damage to the barrier caused by an impact. If there are signs of an extreme impact then a more thorough inspection should be carried out as soon as possible. The barrier sections will need to be replaced in the installation and the damaged sections taken away for further analysis.

Any fasteners that need replacing must meet the correct specification and performance; the bolts must have an 8.8 strength classification (ASTM F1554 Grade 105) and be the correct type of fastener for the application.

Although tears and deep scratches normally do not affect the performance of the barrier system it should be remembered that this may introduce corrosion to the barrier units, so the application of a protective coat of zinc rich paint may be necessary locally in the area of the damage. In case of deep scratches the barrier unit should be replaced. Do not use any sections of barrier that show signs of significant thinning of the barrier skin caused by corrosion.

16. Removal

Refer to below steps for barrier removal.

- Step 1a: Removal of anchor Type A can be achieved by lifting the barrier section itself with a crane or forklift, the anchor pins will come out with the barrier.
- Step 1b: Removal of anchor Type B and can be achieved by either adding a 2nd nut on top of the anchor rod and clamping it or spot welding the existing nut to the anchor rod and rotating the system counter clockwise with an impact wrench.
- Step 2: Remove the security sets
- Step 3: Removal of the individual barrier elements is a reversal of the installation procedure. To separate the barrier sections, start at the last installed element and lift the element keeping it in a horizontal position. The barrier element will separate from the adjacent element. If the section of barrier being removed also lifts the adjacent section with it, place a 50mm high block under the foot of the section being removed (next to the joint), and lower the barrier. It will then separate. The string of barrier elements can also be split anywhere within the string, to allow for another removal point. This can be achieved by lifting an intermediate barrier section and rotating the free end sideways, outside of the barrier string.
- Step 4: Make sure that the bolt on the security set is tightened before transportation.
- Step 5: After removing the barrier elements the remaining anchor holes should be filled. For quick repairs it is advisable to use a one application product like a cold asphalt mix without the need for application of a tack coat, suitable for all weather conditions and which is immediately trafficable. For details on materials and procedures for repairing the road deck surface contact local asphalt specialists. For regulations consult the local road authorities.

17. Permanent installations

Both SafeZone and SafeZone LDS are appropriate as a permanent solution using threaded rod Type B anchors only. Make sure only approved permanent crash cushions are installed for permanent use, do not use temporary crash cushions.

Inspection period for permanent installations

- We suggest that this inspection is carried out at 3 year intervals after the first inspection. Please check with your local jurisdiction if their routine inspection periods are different and go with the lesser period.

Maintenance and inspection

The same methodology would apply for the maintenance of permanent installations as to temporary installations however a number of extra steps should be taken during inspection of permanent installations.

- Inspect for damage.
- Please check anchor shoe housing of barrier if impact has taken place. Inspect the anchor shoe housing to make sure it's still intact and that there has been no tearing of the steel. If damaged replace barrier.
- Please check joint of barrier if impact has taken place. Check that the coupling of the barrier is not damaged. If coupling is damaged replace barrier as necessary.
- Check for alignment. Check that the barrier is in the correct location. Look along length of run and check that each barrier is not sticking out from the next one (*Visual check. Replace or re-install if required*)
- Check for joints connected correctly Inspect. Check that the M20 Nut is in place. Check that the M20 Nut is hand tight. (*Replace or re-install if required*)
- Check Anchored to ground Inspect. Check fixings to anchors are still in place. For threaded rod type anchors make sure that the nut is in place and is hand tight (Re-install if required)
- Check for debris around barrier (*remove if required*)
- Check delineation intact. Check that all delineators are still in place. Check that none are loose. (*Inspect and replace if required*)
- Check for graffiti. Use paint thinner or graffiti removal products if required? (*Clean if required*)
- Check for corrosion. If corrosion has formed on the outside of barrier it may be necessary to inspect the barrier internally. Please check with manufacturer for further instructions if this scenario occurs.

18. Limitations and warnings

SafeZone™ has been rigorously tested and evaluated per the evaluation criteria in the MASH guidelines for a longitudinal barrier. The impact conditions recommended in MASH are intended to address typical inservice collisions.

When properly installed and maintained SafeZone™ allows an impacting vehicle to be contained or re-directed in a safe and predictable manner under the MASH impact conditions. Vehicle impacts that vary from the MASH impact conditions described for longitudinal barriers may result in significantly different results than those experienced in testing.

19. Lifting guide 5.8m barrier

Item	Liftig Chain Length	Max Weight (kg/lbs)	Lifting Capacity
5.8m barrier	Always follow the manufacturers instruction for correct use of the clutch. Shorten the chain using the clutch to ensure the load is level.	Single Element 535.0 kg	Use a suitable crane according offical lifting capacity regulations.

19.1. Lifting the 5.8m barrier from the top

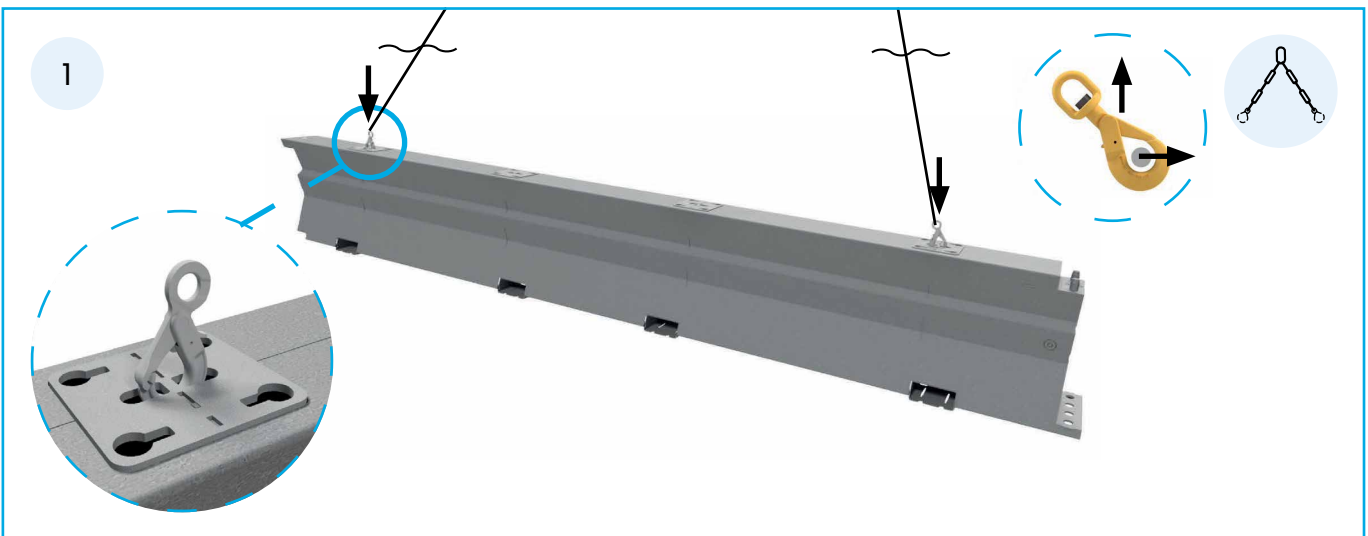

19.2. Lifting the 5.8m barrier from the bottom

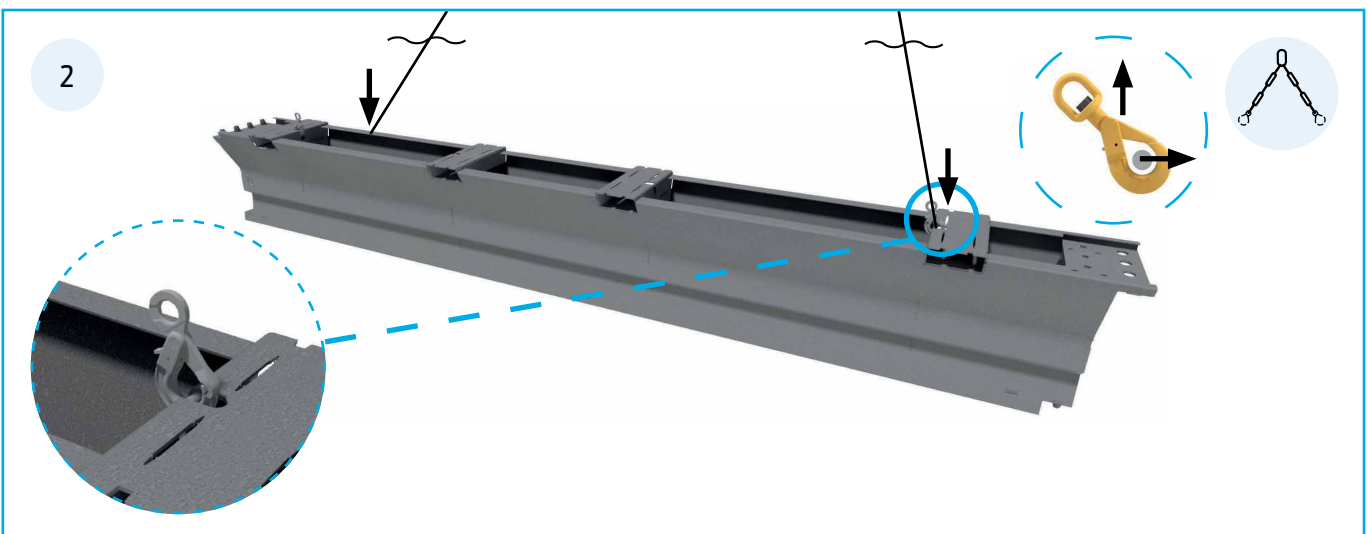

20. Lifting guide 11.6m barrier

Item	Liftig Chain Length	Max Weight (kg/lbs)	Lifting Capacity
11.6m barrier	Always follow the manufacturers instruction for correct use of the clutch. Shorten the chain using the clutch to ensure the load is level.	Doouble Element 1070.0 kg	Use a suitable crane according offical lifting capacity regulations.

20.1. Lifting the 5.8m barrier from the top

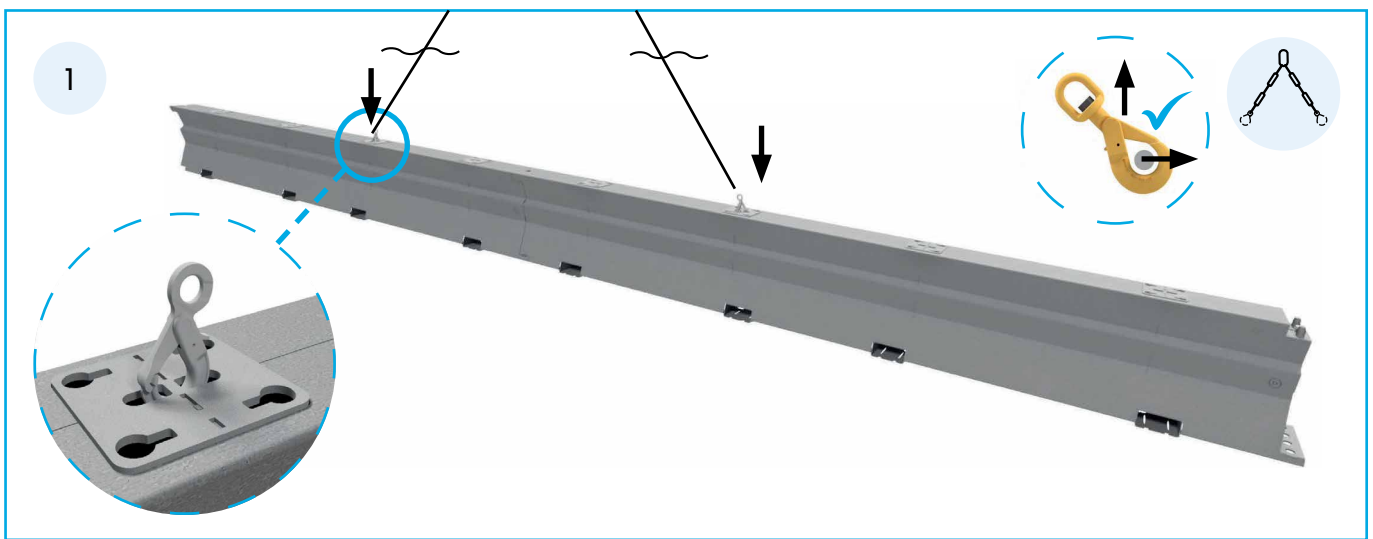

20.2. Lifting the 5.8m barrier from the bottom

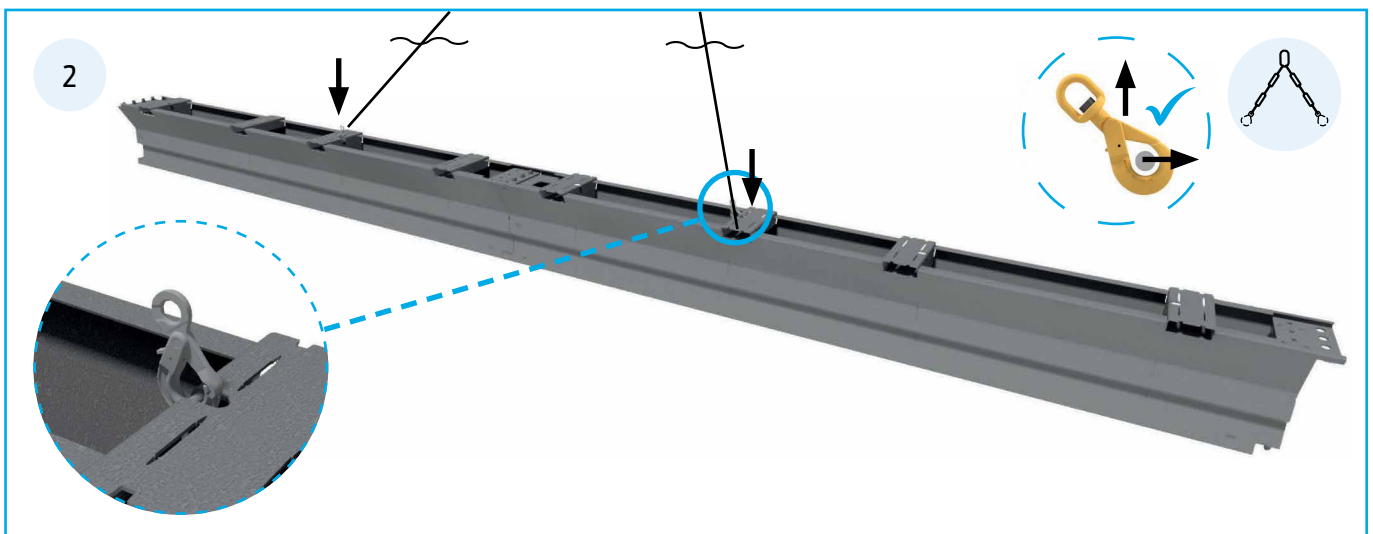

21. Lifting guide ForkLift

Item	Tool
5.8m barrier	Forklift
11.6m barrier	

21.1. Lifting the 5.8m barrier with a forklift

1



21.2. Lifting the 11.6m barrier with a forklift

2



22. Marking

Use original SafeZone parts only. Barriers marked with this logo are SafeZone barriers.



(YY/MM/DD) - production number

The engraving can be found here. See picture below

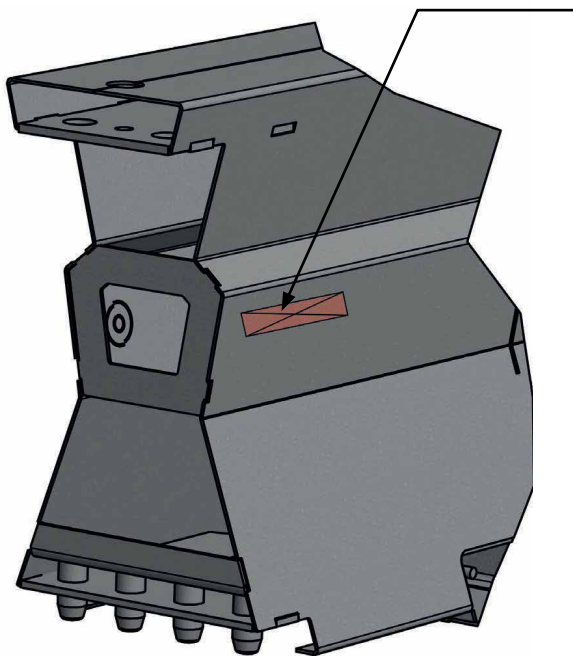

*marking can be
found here*

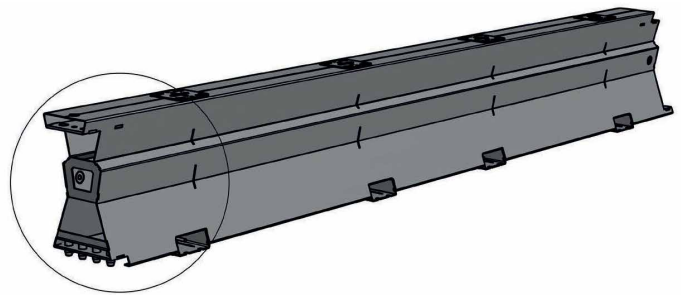

Example Pre-installation checklist

SafeZone must be installed by a qualified installer, with written documentation signed at the end of the installation that it has been installed as per manufacturer manual.

The units are positioned on a cross fall of 8% / 3.60 or less.

All security bolts on the Quick Connect are attached and tightened.

Is an approved crash cushion required?

Workers and equipment are located in the CoPTTM safety clear zone.

Are all hazards located outside the clear zone?

Are all tools removed from site when installation is complete.

If delineation is required it is applied as per MoTSam Part 2.

Clear any debris from under and between the units.

Arrange maintenance inspections as appropriate for location.

Location:

Installed by:

Date:

Installed by:

Date:

Example Installation form

Please fill in and sign this form at the end of the installation.

Project name:			
Job site address:			
Time arrived:			
Time completed:			
Lengths of installs:			
Components installed on site:			
Anchoring:			
End treatments:			
Project manager/ site foreman:			
Traffic control company:			
Tool box meeting held:			
Installers on site:			
Installation checked by:			
Location:			
Installer certificate number:		Date:	
Signed by qualified installer:		Date:	

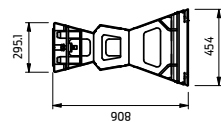
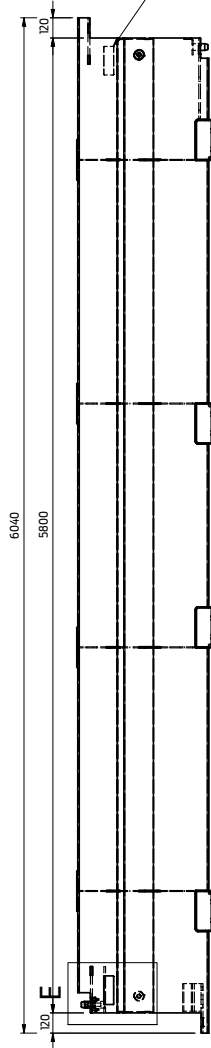
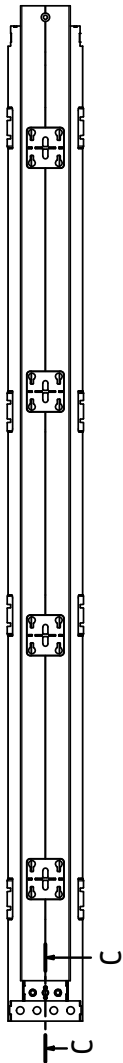
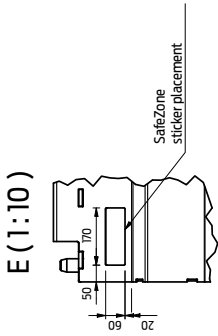

C (1:3)

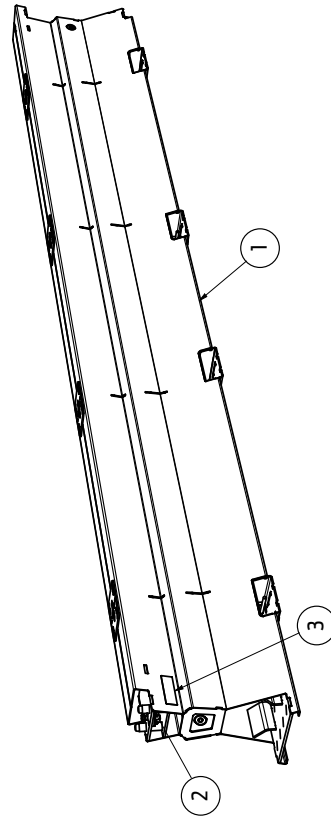
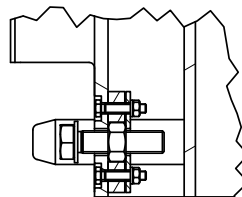

3	2	KE31840019	SafeZone: sticker	Sticker 770x60x0.2mm	Polyester
2	1	AS31840013	SafeZone: security set	Assembly	
1	1	AS31840001	SafeZone: standard barrier	Welding Assembly	
Pos	Qty	Part Number	Title	Description	Material

Author: samuel@jaybro.com	Date: 23-1-2017	UPE: mm	Part Number: AS31840000	Title: SafeZone: standard barrier complete	Revision: A
Checked:	Date:				Scale:
Comments: This drawing is the property of Jaybro Pty Ltd. It is to be used for the purpose for which it is intended and is not to be reproduced or used in any other manner without the prior written permission of Jaybro Pty Ltd.			Description: Assembly		Format: A2
Jaybro Group Pty Ltd 291 Newbridge Crescent, Arundel QLD 42168 TEL: 1300 885 364 www.jaybro.com.au					

Revision	Date	Description
Rev. A	20-09-2017	Pos.3 (sticker) fitted to assembly.

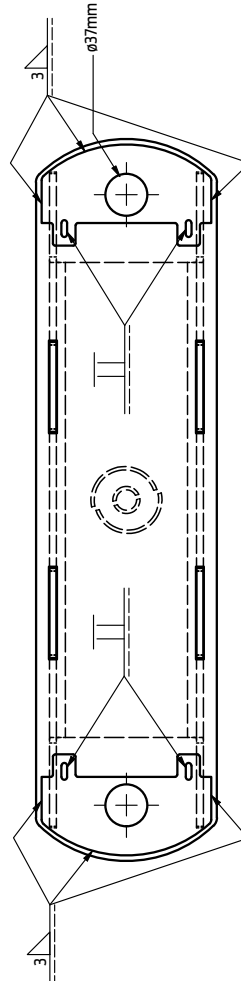
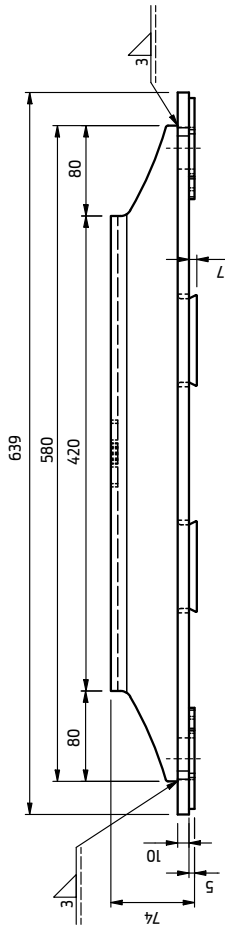
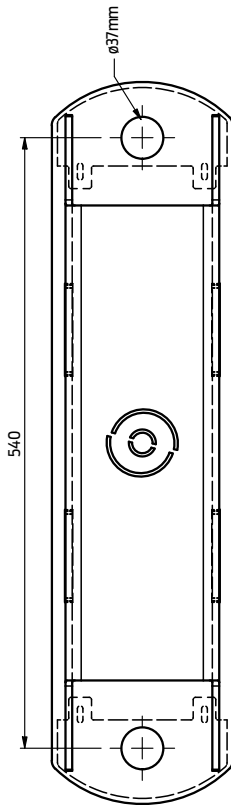
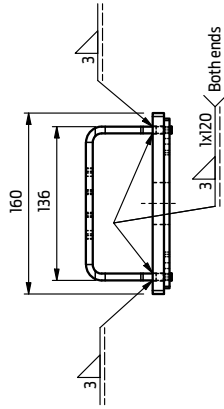
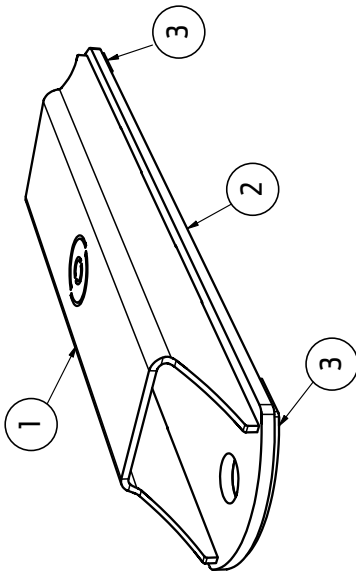



3	2	EP31840022	SafeZone: standard insert	150 x 89.4 x 5mm	S355MC
2	1	EP31840021	SafeZone: standard insert	638.6 x 160 x 10mm	S355MC
1	1	EP31840020	SafeZone: standard insert	990 x 263.4 x 6mm	S355MC
Pos	Qty	Part Number	Title	Description	Material

Material: SafeZone™ safezone smarter. safer.		Part Number: AS31840020		Revision: A
American Projection:		Title: SafeZone: standard insert		Scale:
Author: remaekers	Date: 23-1-2017	Unit: mm	Format: A3	
Checked:	Date:	Description: Welding Composition		
Comments: The copyright of this drawing is reserved by us. It remains the property of the Jaybro Group and may not be reproduced or shown to third parties without permission.				
Jaybro Group Pty Ltd 29 Penelope Crescent, Armidale Park NSW 2148 TEL: 800 885 364 www.jaybro.com.au				

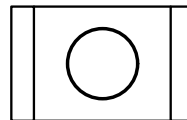
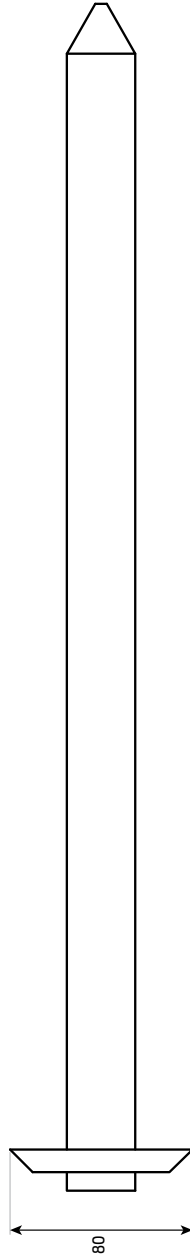
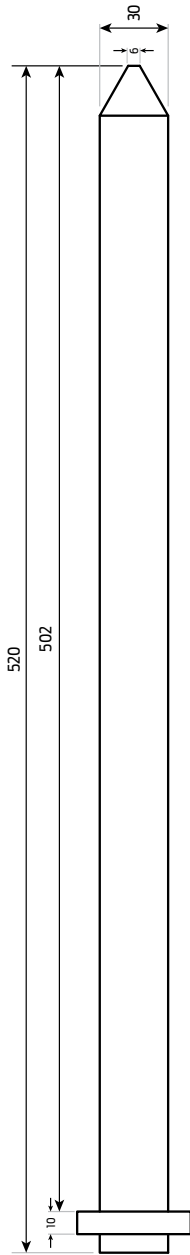
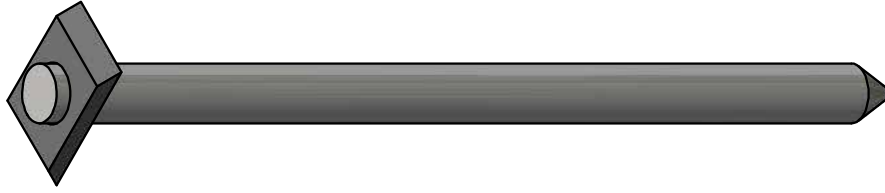
Revision	Date	Description
A	16-03-2020	Pos. 3 Slotted holes: adjusted.



 SafeZone™ <small>safer. simpler. smarter.</small>	Material: American Projection:	Mass: 3.03 kg Part Number: AS31642592	Revision:
		Title: Flat Top Pin	Scale:
Author: namalekern Date: 15-3-2017	Unit: mm	Description: Flat Top Pin	Format: A3
Checked:	Comments: Hot-dip galvanise according to EN 1461. <small>The copyright of this drawing is reserved by us. It remains the property of the Jaybro Group and may not be reproduced or shown to third parties without permission.</small>	Jaybro Group Pty Ltd 29 Penelope Crescent, Airdie Park NSW 2148 TEL: 1300 885 364 www.jaybro.com.au	

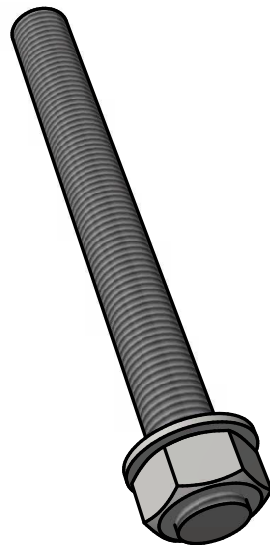
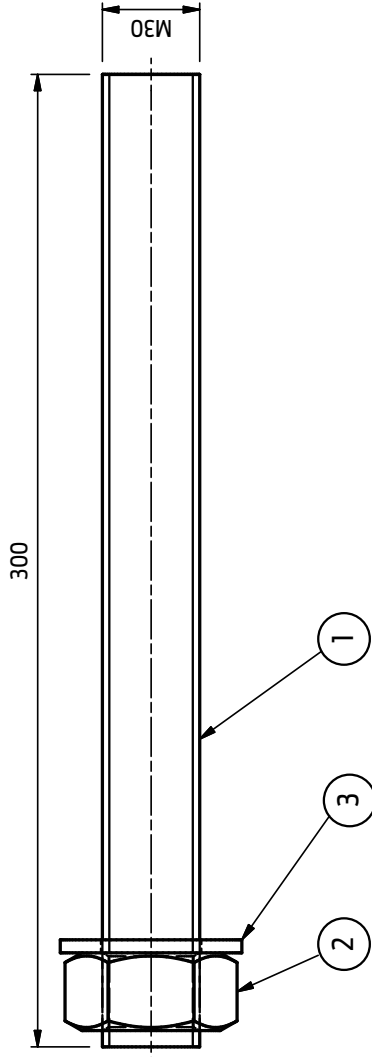

3	2	SafeZone; M30 Anchor Bolt	M30 Washer	DIN125
2	1	SafeZone; M30 Anchor Bolt	M30 Hex Nut	DIN934
1	1	SafeZone; M30 Anchor Bolt	M30 Stud x 300mm	DIN976
Pos	Qty	Part Number	Description	Material

			Material: American Projection: Mass: 1.95 kg	Part Number: AS31840030	Revision:
Author: ramaekersn	Date: 10-7-2017	Unit: mm	Title: SafeZone; M30 Anchoring	Scale:	Format: A4
Checked:	Date:	Description: Anchor Bolt M30 x 300mm			
Comments: The copyright of this drawing is reserved by us. It remains the property of the Jaybro Group and may not be reproduced or shown to third parties without permission.					
Jaybro Group Pty Ltd 29 Penelope Crescent, Airdell Park NSW 2148 TEL: 1300 885 364 www.jaybro.com.au					

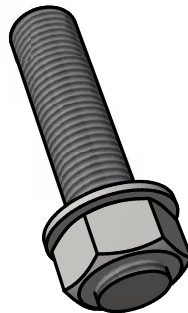
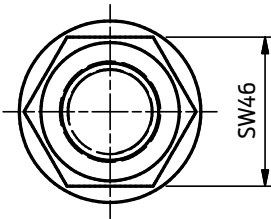
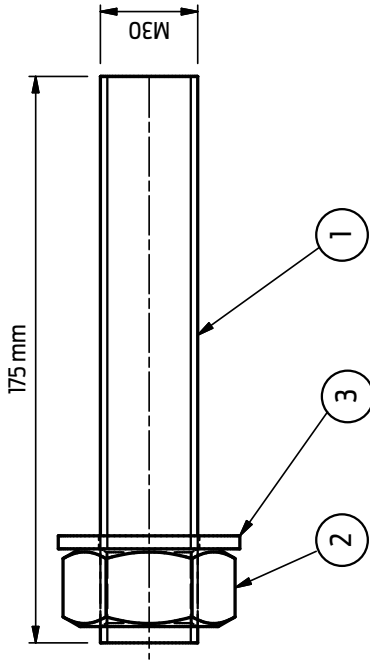

3	1	SafeZone; M30 Anchoring	M30 Stud x 175mm	DIN976
2	1	SafeZone; M30 Anchoring	M30 Washer	DIN125
1	1	SafeZone; M30 Anchoring	M30 Hex Nut	DIN934
Pos	Qty	Part Number	Description	Material

			Material: American Projection:	Mass: 1.95 kg	Revision
SafeZone™ safer, simpler, smarter.		Part Number: AS31840031		Title: SafeZone; Anchoring	Scale:
Author: ramaekersn	Date: 10-7-2017	Unit: mm	Description: Anchor Bolt M30 x 175mm		
Checked:	Date:	Format A4			
Comments: The copyright of this drawing is reserved by us. It remains the property of the Jaybro Group and may not be reproduced or shown to third parties without permission.					
Jaybro Group Pty Ltd 29 Penelope Crescent, Airdell Park NSW 2148 TEL: 1300 885 364 www.jaybro.com.au					

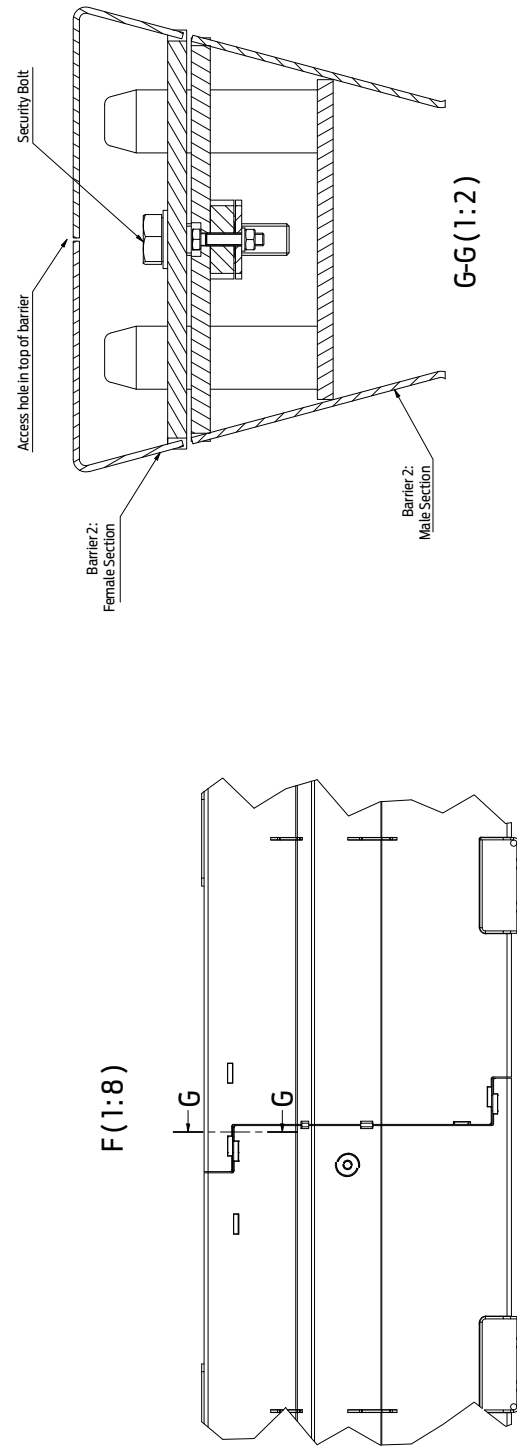
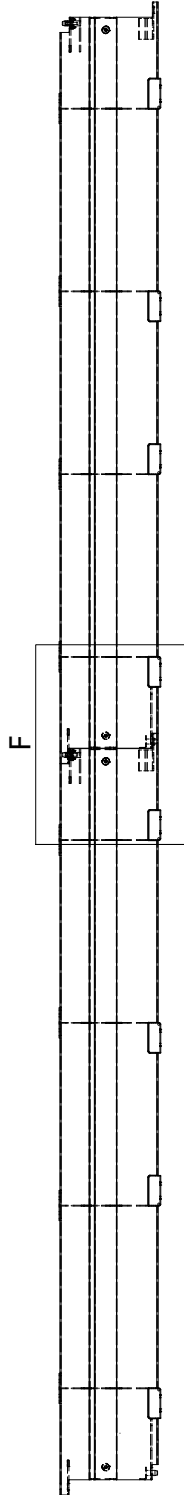
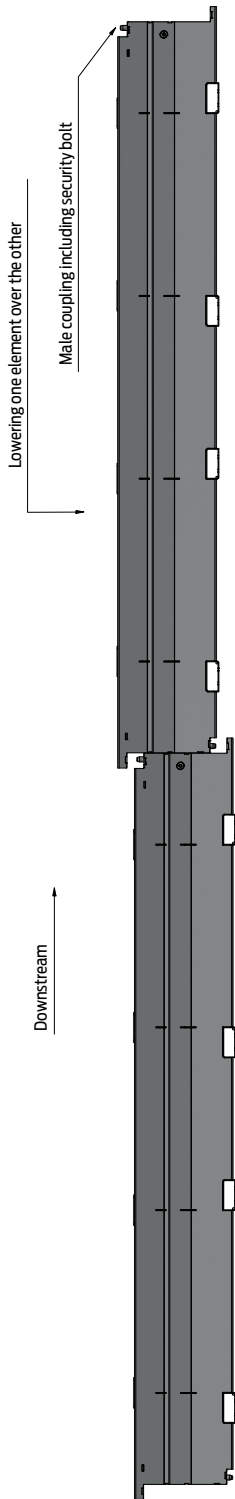

				Part Number: SafeZone		Revision	
Author: m.mulligan		Date: 15-3-2017		Unit: mm		Scale:	
Checked:		Date:		Title: Connecting 2 Barriers		Description:	
Comments:		This copyright critical drawing is used without permission by persons of the Jaybro Group and is not to be reproduced or shown to third parties without permission.		Description: Security Set		Format: A2	
Jaybro Group Pty Ltd 79 Pennington Crescent, Armadale Park NSW 2143 TEL: 1300 885 364 www.jaybro.com.au							

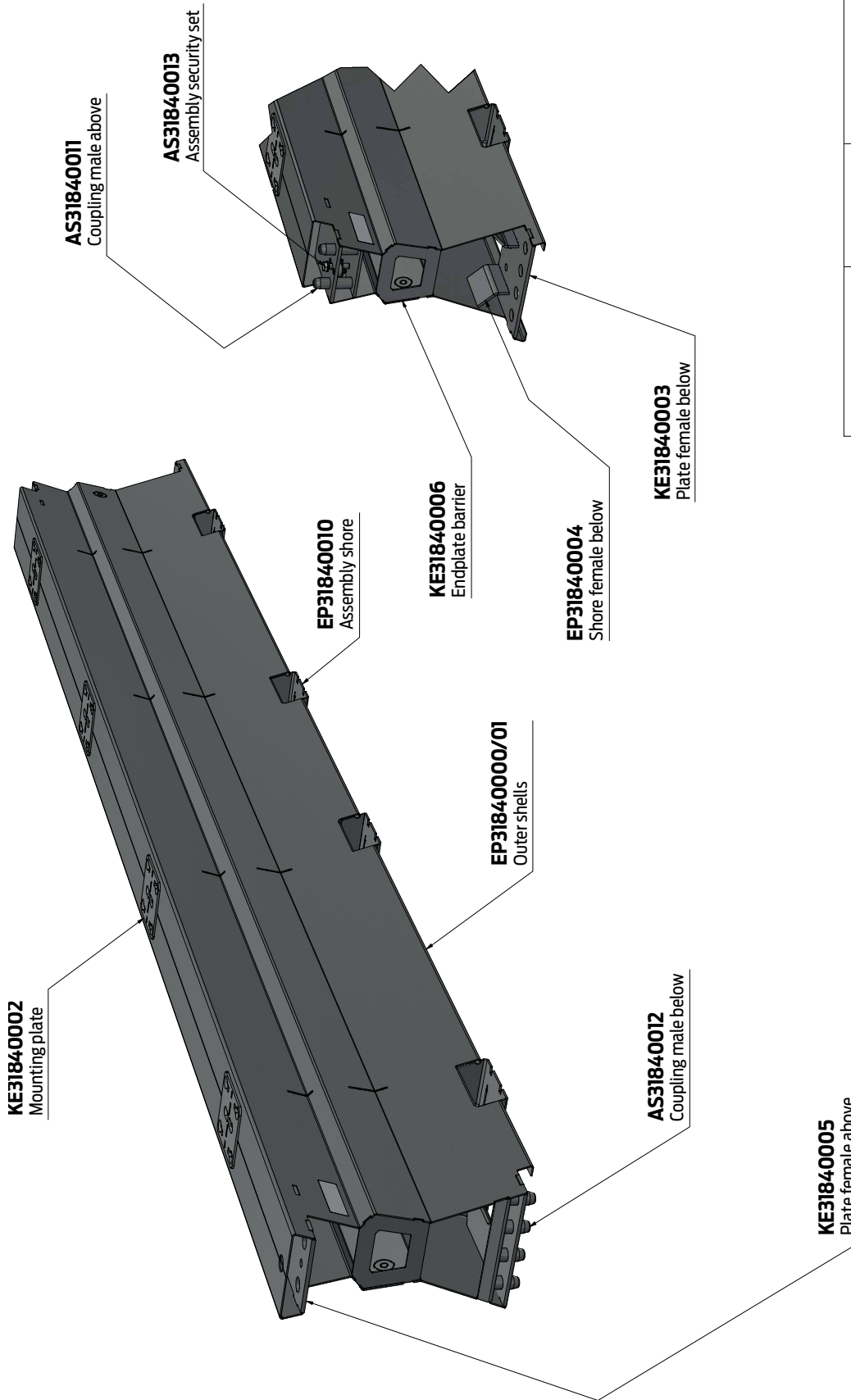

SafeZone™ The world's most advanced, intelligent, barrier.		Material: American Protection		Part Number: SafeZone		Mass: 0.9813 kg		Revision	
Author: amw@jaybro.com	Date: 15-3-2017	Unit: mm	Title: SafeZone: Standard Barrier Complete		Description: Security Set		Scale: A2		
Checked:	Date:	Comments: The copyright of this drawing is reserved by us. It remains the property of the Jaybro Group and may not be reproduced or shown to third parties without permission.		Description:		Format: A2			
<small> Jaybro Group Pty Ltd, 110 Endeavour Promenade, Ascot Vale, VIC 3089, Australia. Tel: +61 3 9399 8866. Fax: +61 3 9399 8867. Email: sales@jaybro.com.au </small>									

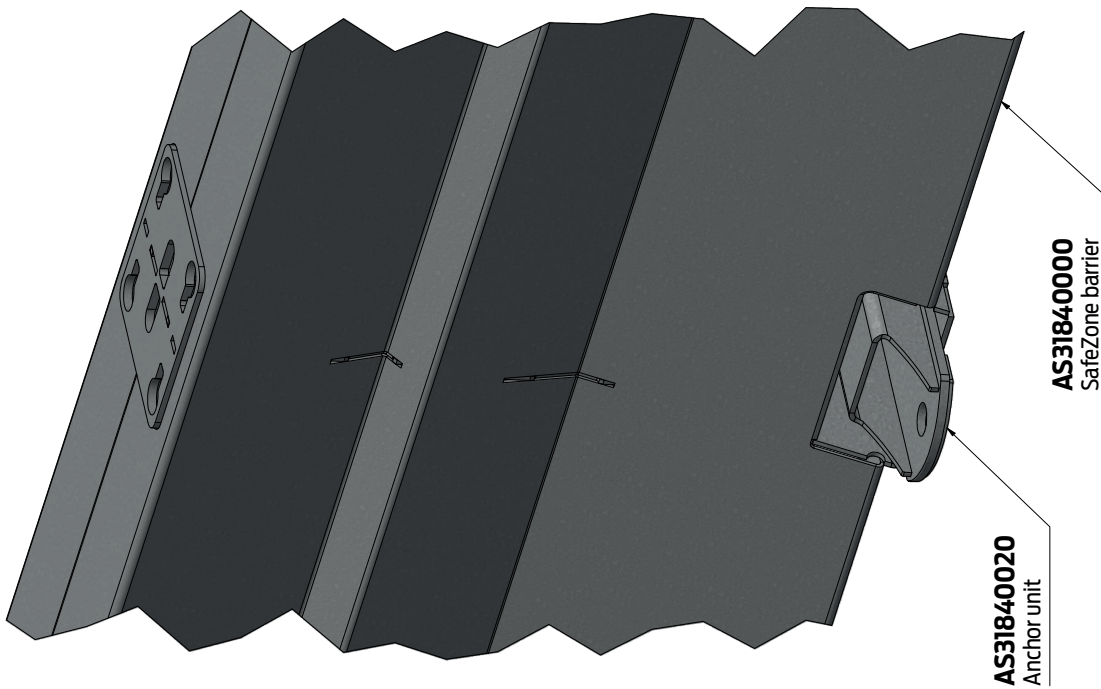
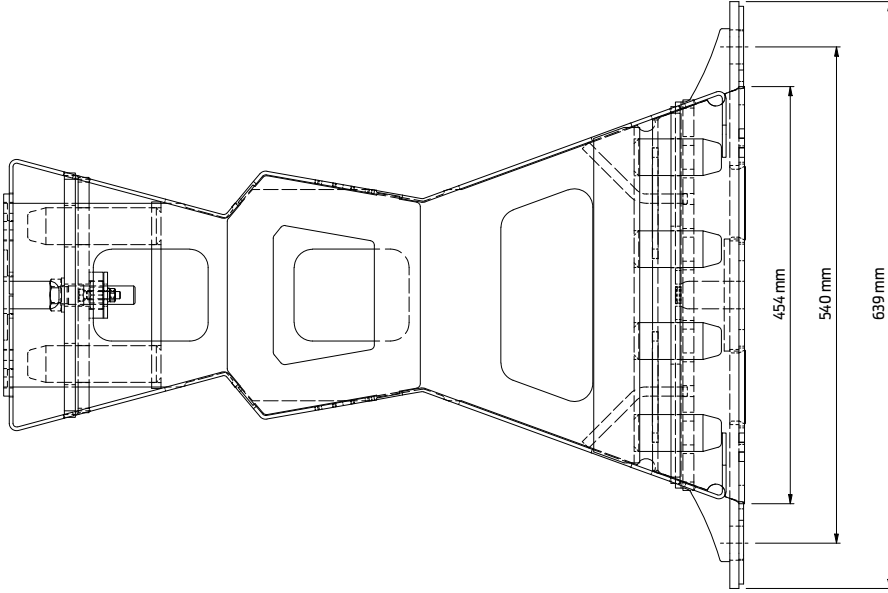

		SafeZone™ American Projectors		Miss N/A	
Author: amakaren		Date: 15-3-2017		Part Number: SafeZone	
Checked:		Date:		Title: SafeZone	
Unit: mm		Scale:		Revision:	
Comments: This drawing is for information only. It is not intended for construction. It is not intended for use in any other way without the express written permission of Jaybro Group Pty Ltd.		Reviser: Including anchor unit		Format: A2	
Jaybro Group Pty Ltd 29 Penelope Crescent, Arncliffe NSW 2168 TEL: 1300 885 364 www.jaybro.com.au					

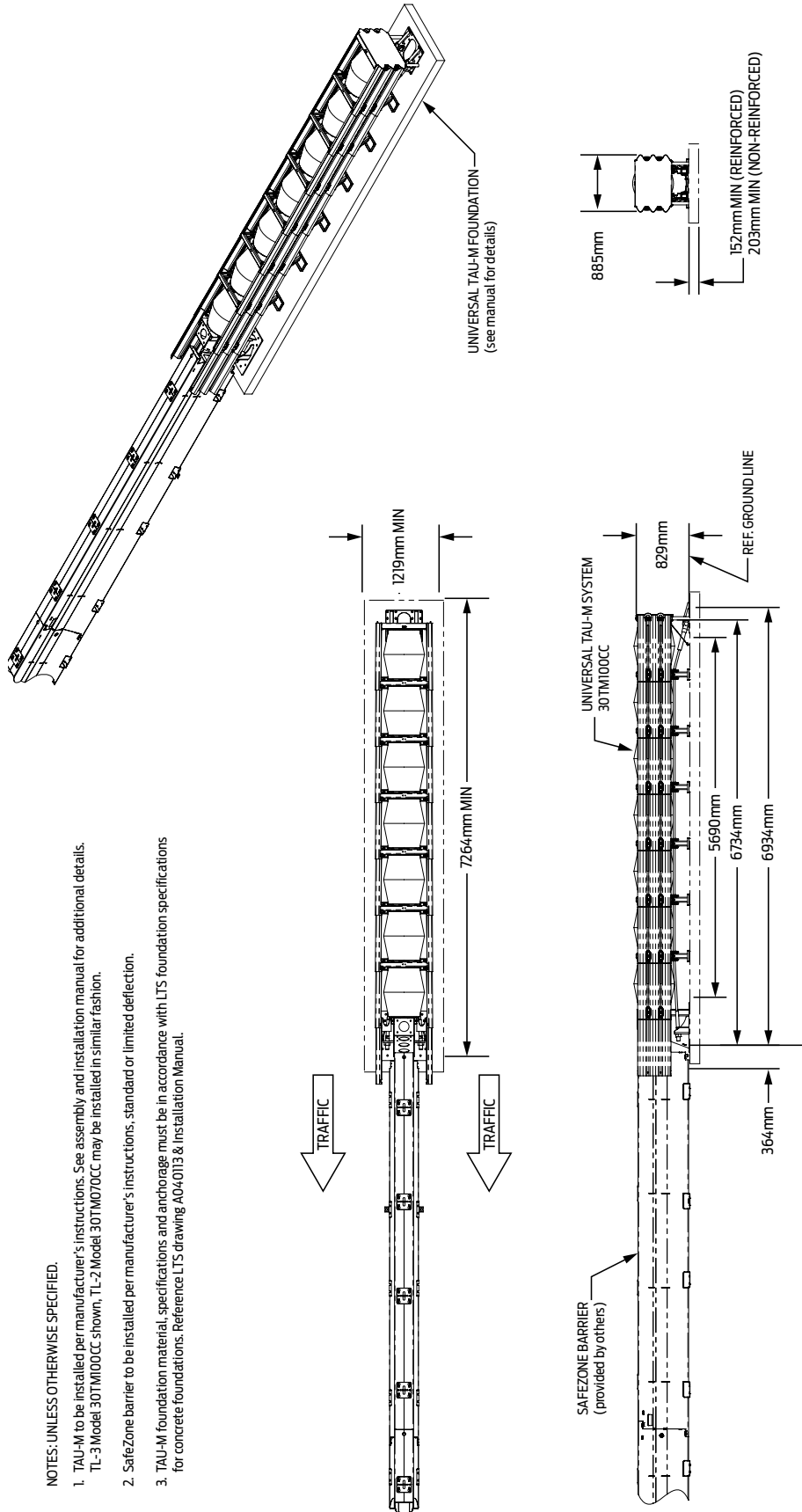

NOTES: UNLESS OTHERWISE SPECIFIED.

1. TAU-M to be installed per manufacturer's instructions. See assembly and installation manual for additional details. TL-3 Model 30TM100CC shown, TL-2 Model 30TM070CC may be installed in similar fashion.
2. SafeZone barrier to be installed per manufacturer's instructions, standard or limited deflection.
3. TAU-M foundation material, specifications and anchorage must be in accordance with LTS foundation specifications for concrete foundations. Reference LTS drawing A040113 & Installation Manual.

This drawing is provided for informational purposes only and is based upon information provided to Jaybro by the customer (which may not reflect, among other things, certain information that could be obtained via an in-person visit to, or familiarity with, the installation site). Neither Jaybro nor any of its affiliates is liable for any direct, indirect, incidental, consequential, or punitive damages arising out of or related to the customer's access to, use of, or reliance upon this drawing. This drawing is not a substitute for and should not be used in conjunction with, (1) the manufacturer's instructions, or (2) any other drawings or specifications. The product must be assembled and installed in a manner not inconsistent with the Procedures and must comply with federal, state and local standards. Installation and any modifications to the product should be reviewed and approved by the Authority.

		Material: Third Angle Projection		DWG NO.	Revision
		Title: Universal TAU-M transitioned to SafeZone Barrier, Concrete, UniDirectional		BSI-1905024-AP	1
Drawn by: BRD	Date: 22/05/2019	Unit: mm	Scale:		
Approved by: JMT	Date: 22/05/2019	Comments:	Scale:		
The copyright of this drawing is reserved by us. It remains the property of the Jaybro Group and may not be reproduced or drawn to third parties without permission.			Scale:		
Jaybro Group Pty Ltd 29 Pentridge Crescent, Annfield Park NSW 2148 TEL: 1300 885 364 www.jaybro.com.au			Scale:		
Revision			Scale:		
Rev.	Date	ECN#	Scale:		
1	21-05-2019	AP 01437	Scale:		

NOTES: UNLESS OTHERWISE SPECIFIED.

1. TAU-M to be installed per manufacturer's instructions. See assembly and installation manual for additional details. TL-3 Model 30TM100CC shown. TL-2 Model 30TM070CC may be installed in similar fashion.
2. SafeZone barrier to be installed per manufacturer's instructions, standard or limited deflection.
3. TAU-M foundation material, specifications and anchorage must be in accordance with LTS foundation specifications for concrete foundations. Reference LTS drawing A040113 & Installation Manual.
4. Blockouts per local standards. Blockout to be field trimmed to fit.
5. Transition panels, blockouts, custom bracket and three beam terminal connector attached through barrier with 16mm threaded rods (BSI-1309061-00) with beam washers (400Z051), flat washers (2001636) and nuts (400116), threaded rod may be field trimmed.
6. Attach custom bracket to three beam terminal connector with 16mm x 50mm bolts (400115) with beam washers (400Z051), flat washers (2001636) and nuts (400116).

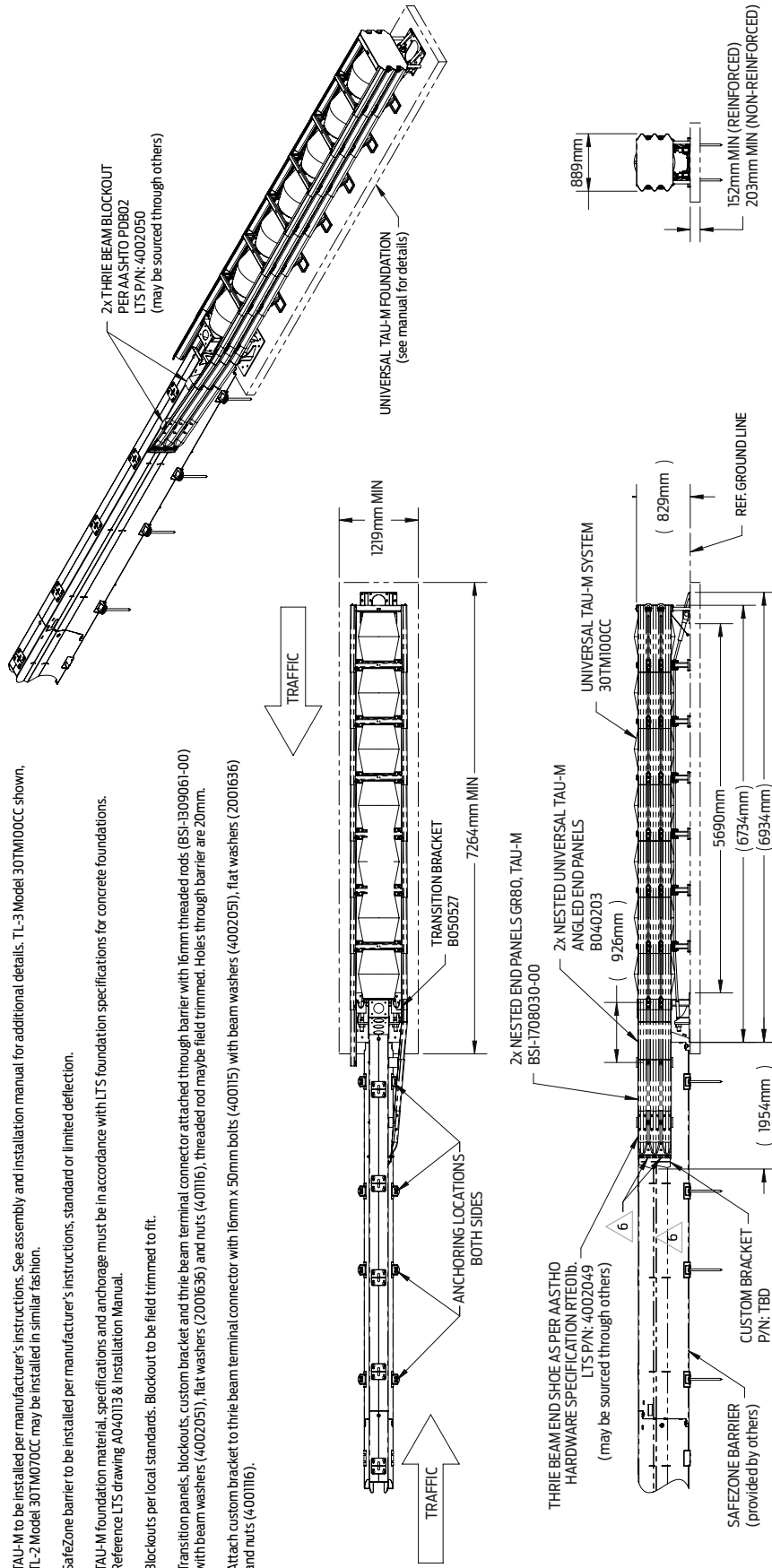

			Material: Third Angle Projection	DWG NO.	Revision
				Date: 2/05/2019 Approved by: AMT	Title: Universal TAU-M transitioned to SafeZone Barrier, Concrete, Bi-Directional
Drawn by: BRO Approved by: AMT Date: 2/05/2019	Unit: mm	Comments: The copyright of this drawing is reserved by Jaybro. It remains the property of the Jaybro Group and may not be reproduced or shown to third parties without permission. Jaybro Group Pty Ltd 29 Pennington Crescent, Arndell Park NSW 2148 TEL: 1300 885 364 www.jaybro.com.au			

Revision	Date	ECN#
1	21-05-2019	AP 01437

The drawings are provided for informational purposes only and is based on information provided to us by the customer (which may not reflect, among other things, certain information that could be obtained via an on-site visit to, or familiarity with, the installation site). Neither Jaybro nor any of its affiliates is liable for any direct, indirect, incidental, consequential, or punitive damages arising out of or related to the customer's access to, use of, or reliance upon this drawing. This drawing is a substitute for, and should be used in conjunction with, (1) the previously provided manufacturer assembly procedures (the "Procedures") and (2) the professional judgement of a qualified professional engineer or architect. The drawings and any modifications to the product should be reviewed and approved by the Authority. Standards, installation and any modifications to the product should be reviewed and approved by the Authority.

NOTES: UNLESS OTHERWISE SPECIFIED.

1. TAU-M to be installed per manufacturer's instructions. See assembly and installation manual for additional details. TL-3 Model 30TM100CC shown. TL-2 Model 30TM70CC may be installed in similar fashion.
2. SafeZone barrier to be installed per manufacturer's instructions, standard or limited deflection.
3. TAU-M foundation material, specifications and anchorage must be in accordance with LTS foundation specifications for asphalt foundations. Reference LTS drawing A040113 & Installation Manual.
4. Blockouts per local standards. Blockout to be field trimmed to fit.
5. Transition panels, blockouts, custom bracket, and three beam terminal connector attached through barrier with 16mm threaded rods (BS-1309061-00) with beam washers (4002051), flat washers (2001636) and nuts (400116), threaded rod may be field trimmed. Holes through barrier are 20mm.
6. Attach custom bracket to three beam terminal connector with 16mm x 50mm bolts (400115) with beam washers (4002051), flat washers (2001636) and nuts (400116).

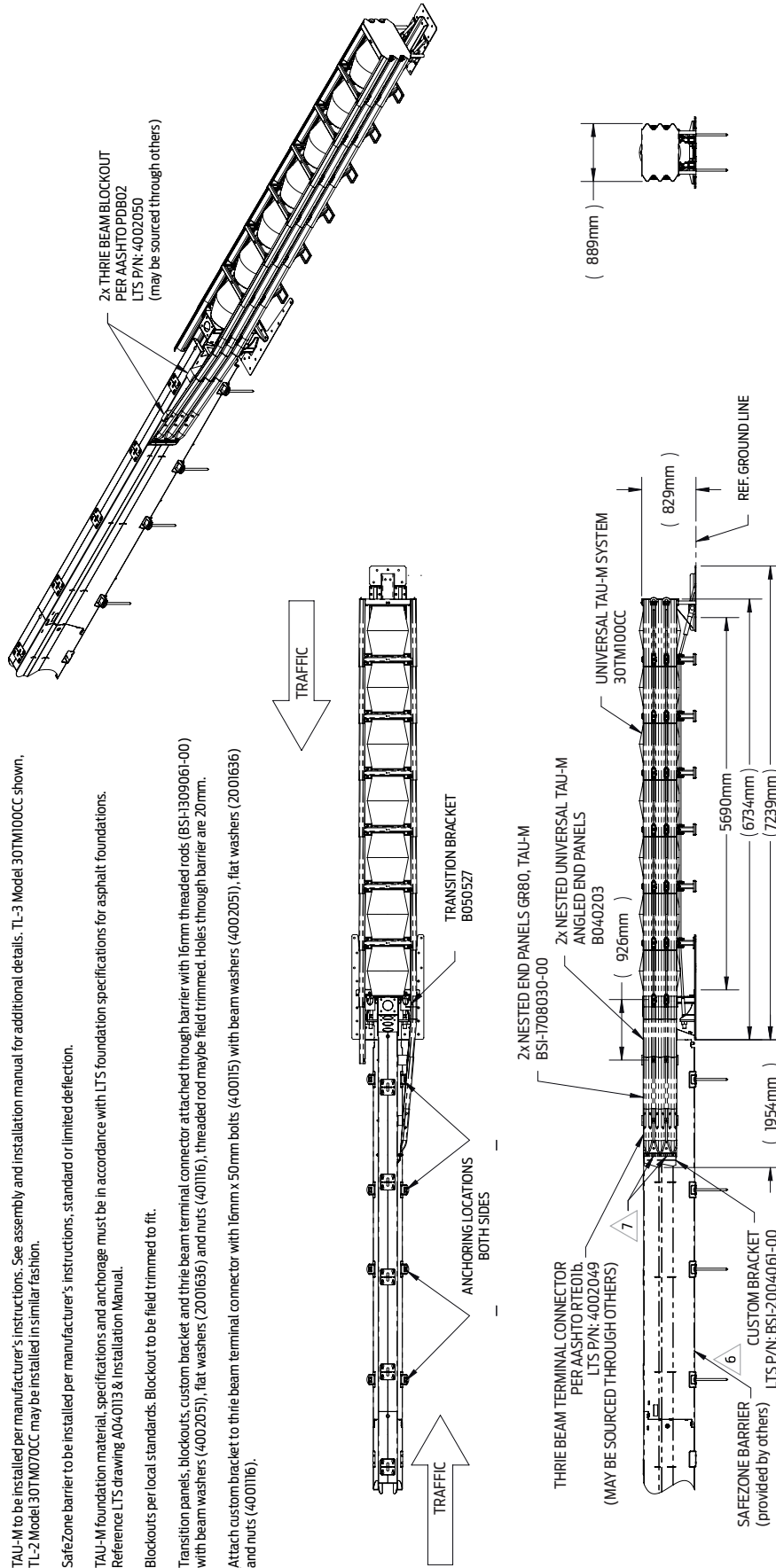

	Material:	Misc/N/A	DWG NO.	BSI-1905023-AP	Revision	1
	Third Angle Projection		Title:	Universal TAU-M transitioned to SafeZone Barrier, Asphalt, Bi-Directional	Scale:	
Drawn by: BRD	Date: 2/05/2019	Unit:	mm		Site:	B
Approved by: JMT	Date: 2/05/2019	Comments:				
The copyright of this drawing is reserved by us. It remains the property of the Jaybro Group and may not be reproduced or shown to third parties without permission. Jaybro Group Pty Ltd 29 Penelope Crescent, Ambull Park NSW 2148 TEL: 1300 885 364 www.jaybro.com.au						

Revision	Date	ECN#
1	21-05-2019	AP 01437

This drawing is provided for informational purposes only and is based upon information provided to Jaybro by the customer. Jaybro does not warrant the accuracy or completeness of the information provided. Jaybro is not responsible for any indirect, incidental, consequential, or punitive damages arising out of or related to the customer's access to, use of, or reliance upon this drawing. This drawing is not a substitute for, and should be used in conjunction with, (1) the previously provided installation assembly procedures (the "Procedures") and (2) the professional judgement of the customer and/or the responsible local highway authority (the "Authority"). The product must be assembled and installed in accordance with the "Procedures" and the "Authority". The product must be assembled and installed in accordance with any modifications to the product that have been reviewed and approved by the Authority.

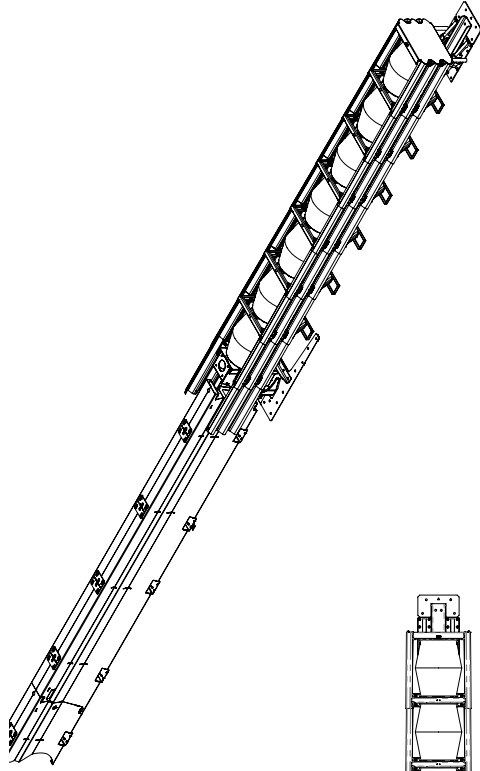

- NOTES: UNLESS OTHERWISE SPECIFIED.
1. TAU-M TO BE INSTALLED PER MANUFACTURER'S INSTRUCTIONS. SEE ASSEMBLY AND INSTALLATION MANUAL FOR ADDITIONAL DETAILS. TL-3 MODEL 30TM100CA SHOWN. TL-2 MODEL 30TM070CA MAY BE INSTALLED IN SIMILAR FASHION.
 2. SAFEZONE BARRIER TO BE INSTALLED PER MANUFACTURER'S INSTRUCTIONS. STANDARD OR LIMIT DEFLECTION.
 3. TAU-M FOUNDATION MATERIAL, SPECIFICATIONS AND ANCHORAGE MUST BE IN ACCORDANCE WITH ITS FOUNDATION SPECIFICATIONS FOR ASPHALT FOUNDATIONS. REFERENCE LT'S DRAWING AD40113 & INSTALLATION MANUAL.

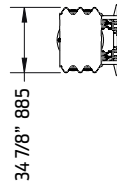
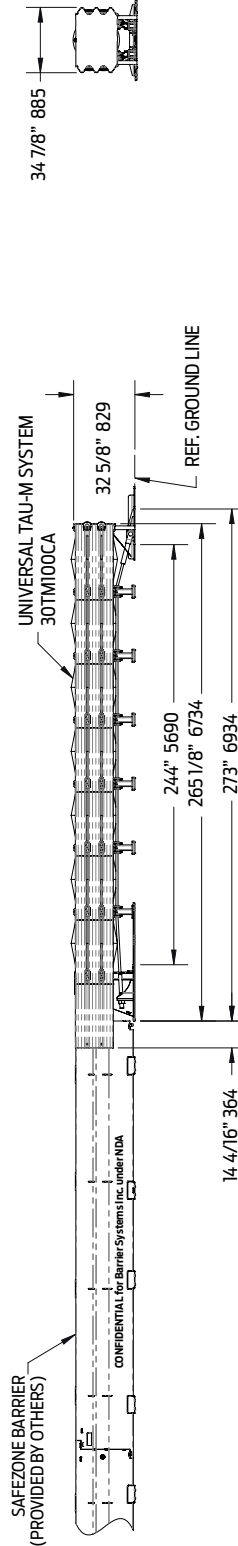
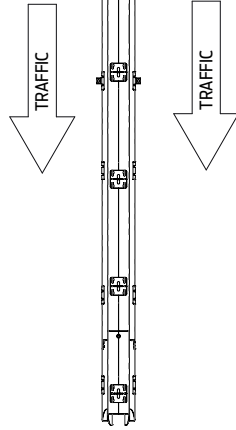

			Material: Third Angle Projection	Mass: N/A
DWG NO. BSI-1905025-AP	Revision 1	Title: Universal TAU-M transitioned to SafeZone Barrier. Asphalt, Unidirectional	Scale: 1:60	Site B
Drawn by: BRD Approved by: JMT Date: 22/05/2019 Date: 22/05/2019	Unit: mm	Comments: The copyright of this drawing is reserved by us. It remains the property of the Jaybro Group and may not be reproduced or shown to third parties without permission. Jaybro Group Pty Ltd 70 Bowral Street Armidale NSW 2341 TEL: 1300 885 364 www.jaybro.com.au		

Revision	Date	ECN#	AD #14/37
1	21-05-2019		

This drawing is provided for informational purposes only and is based upon information provided to Jaybro by the customer (which may not reflect, among other things, certain information that could be obtained via an in-person inspection of the site). Jaybro is not responsible for the accuracy of the information provided to Jaybro, and Jaybro does not warrant, represent, or make any claim of liability for the accuracy of the information provided to Jaybro. Use of or reliance upon this drawing is not a substitute for, and should be used in conjunction with, (1) the previously provided installer/assembly procedures (the "Procedures") and (2) the professional judgment of the customer and/or the responsible local highway authority (the "Authority"). The product must be assembled and installed in a manner not inconsistent with the Procedures and must comply with federal, state, and local

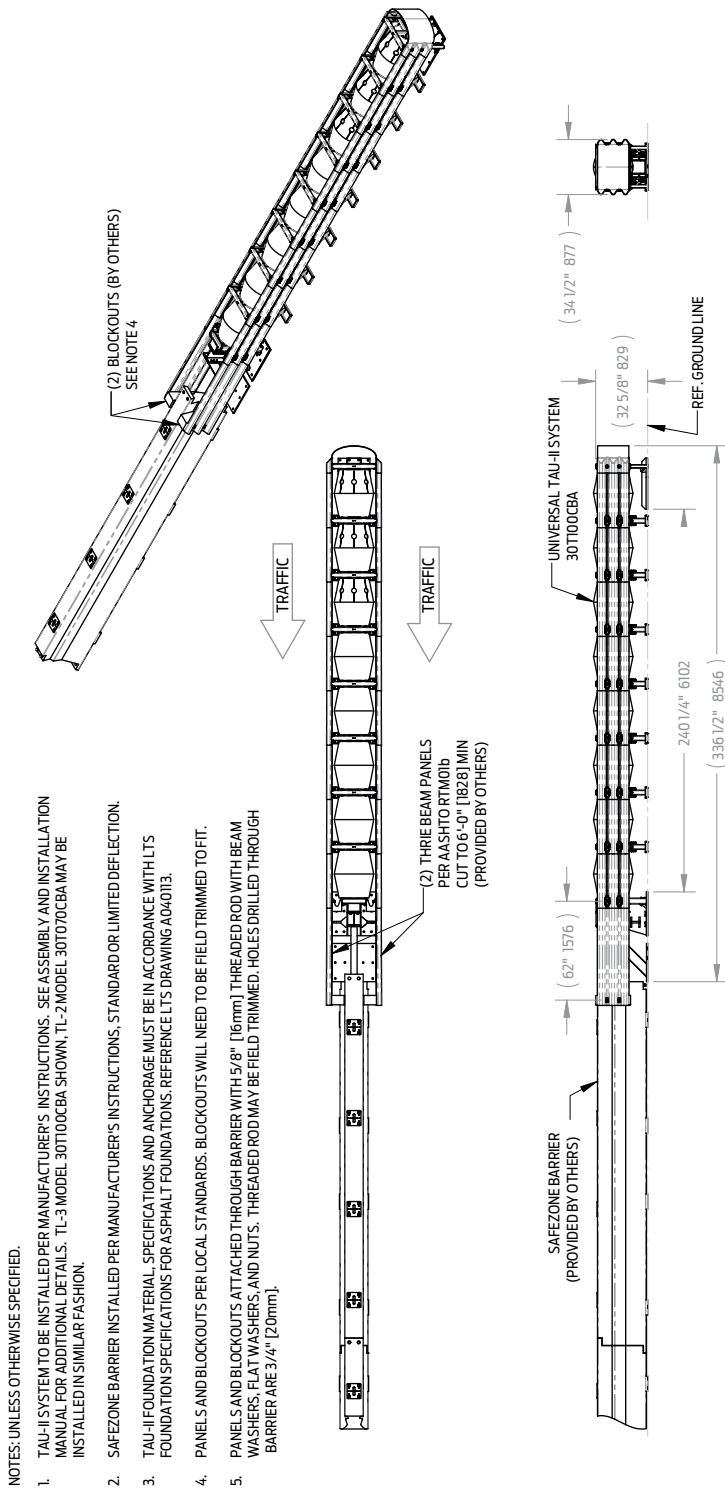

- NOTES: UNLESS OTHERWISE SPECIFIED.
1. TAU-II SYSTEM TO BE INSTALLED PER MANUFACTURER'S INSTRUCTIONS. SEE ASSEMBLY AND INSTALLATION MANUAL FOR ADDITIONAL DETAILS. TL-3 MODEL 30T100CBA SHOWN. TL-2 MODEL 30T070CBA MAY BE INSTALLED IN SIMILAR FASHION.
 2. SAFEZONE BARRIER INSTALLED PER MANUFACTURER'S INSTRUCTIONS. STANDARD OR LIMITED DEFLECTION.
 3. TAU-II FOUNDATION MATERIAL, SPECIFICATIONS AND ANCHORAGE MUST BE IN ACCORDANCE WITH ITS FOUNDATION SPECIFICATIONS FOR ASPHALT FOUNDATIONS. REFERENCE LT'S DRAWING A040113.
 4. PANELS AND BLOCKOUTS PER LOCAL STANDARDS. BLOCKOUTS WILL NEED TO BE FIELD TRIMMED TO FIT.
 5. PANELS AND BLOCKOUTS ATTACHED THROUGH BARRIER WITH 5/8" (16mm) THREADED ROD WITH BEAM WASHERS, FLAT WASHERS, AND NUTS. THREADED ROD MAY BE FIELD TRIMMED. HOLES DRILLED THROUGH BARRIER ARE 3/4" (20mm).

This drawing is provided for informational purposes only and is based upon information provided to Jaybro by the customer (which may not reflect, among other things, certain information that could be obtained via a in-person visit to, or familiarity with, the installation site). Neither Jaybro nor any of its affiliates is liable for any direct, indirect, incidental, consequential, or punitive damages arising out of or related to the customer's access to, use of, or reliance on this drawing. The customer acknowledges that the use of this drawing is at the customer's sole risk and that the customer and/or the responsible local highway authority (the "Authority"). The product must be assembled and installed in a manner not inconsistent with the Procedures and must comply with federal, state and local standards. Installation and any modifications to the product should be reviewed and approved by the Authority.

				Material: Mass: N/A	Revision 1
	Date: 08-09-2018 Approved by: GAD	Date: 08-09-2018	Unit: mm	Title: Universal Tau-II, Transitioned To Safezone Barrier, Asphalt, Undirectional	Scale: 1:60
Comments: This drawing is provided for informational purposes only. It remains the property of the Jaybro Group and may not be reproduced or shown to third parties without permission.					Size B
Jaybro Group Pty Ltd 29 Pennington Crescent, Amble Park NSW 2148 TEL: 1300 885 364 www.jaybro.com.au					

Revision	Date	ECN#
1	08-09-2018	AP 01367

- NOTES: UNLESS OTHERWISE SPECIFIED.
1. TAU-II SYSTEM TO BE INSTALLED PER MANUFACTURER'S INSTRUCTIONS. SEE ASSEMBLY AND INSTALLATION MANUAL FOR ADDITIONAL DETAILS. TL-3 MODEL 30T100CBC SHOWN. TL-2 MODEL 30T1070CBC MAY BE INSTALLED IN SIMILAR FASHION.
 2. SAFEZONE BARRIER INSTALLED PER MANUFACTURER'S INSTRUCTIONS, STANDARD OR LIMITED DEFLECTION.
 3. TAU-II FOUNDATION MATERIAL, SPECIFICATIONS, AND ANCHORAGE MUST BE IN ACCORDANCE WITH LITS FOUNDATION SPECIFICATIONS FOR CONCRETE FOUNDATIONS. REFERENCE LITS DRAWING A0-40113.

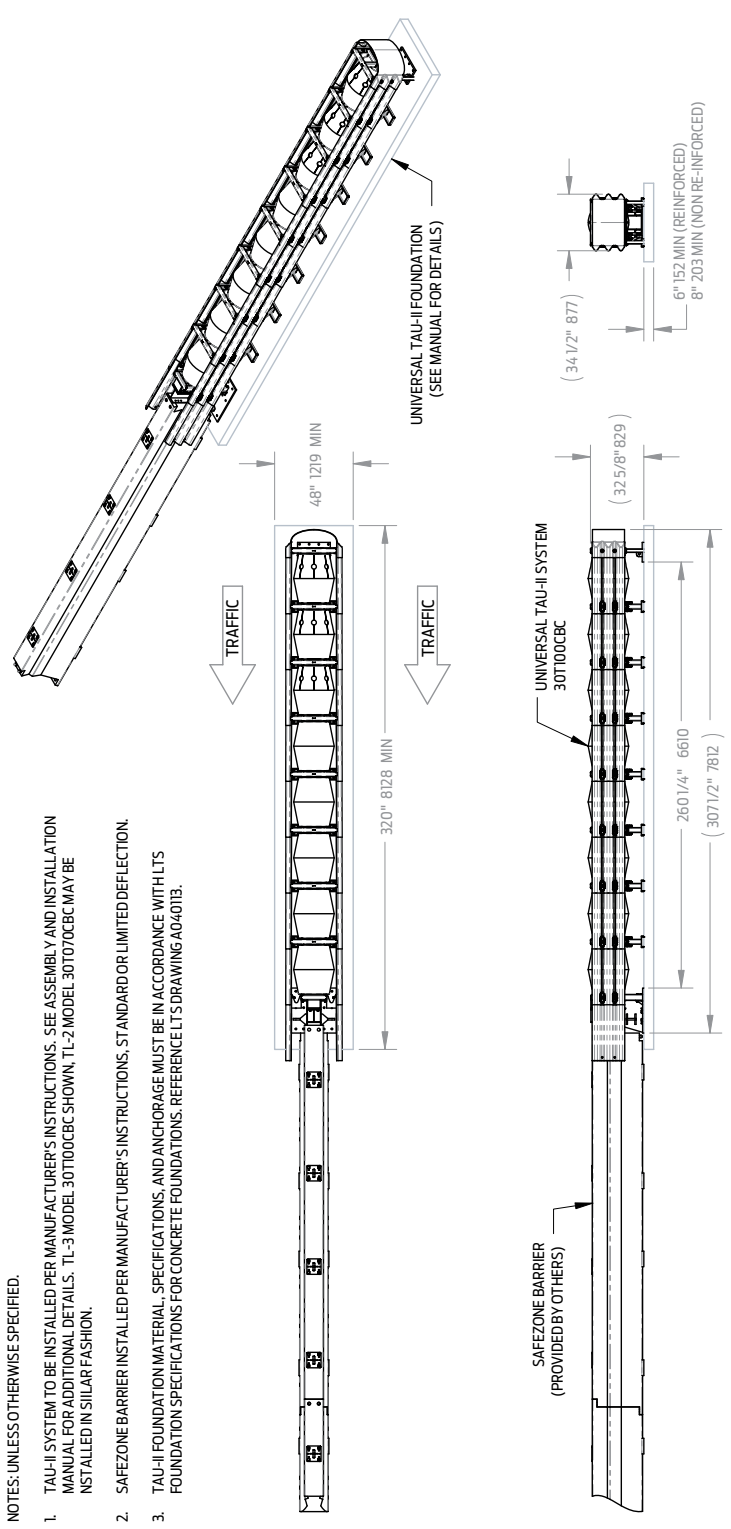

Material: SafeZone™ safer, simpler, smarter.		DWG NO. BSI-1808052-AP		Revision 1	
Thru-Angle Projection		Title: Universal Tau-II, Transitioned To Safezone Barrier, Concrete, Unidirectional		Scale: 1:60	
Drawn by: NMB	Date: 08/09/2018	Unit: mm	Size B		
Approved by: GAD	Date: 08/09/2018	Comments:			
This drawing is the property of Jaybro Group Pty Ltd. It is to be used only for the project specified and may not be reproduced or loaned to third parties without permission.					
Jaybro Group Pty Ltd 29 Pennington Crescent, Amble Park NSW 2148 TEL: 1300 885 364 www.jaybro.com.au					

Revision	Date	ECN#
1	08-09-2018	AP 01367

This drawing is provided for informational purposes only and is based upon information provided to Jaybro by the customer (which may not reflect, among other things, certain information that could be obtained via a in-person visit to, or familiarity with, the installation site). Neither Jaybro nor any of its affiliates is liable for any direct, indirect, incidental, consequential, or punitive damages arising out of or related to the customer's access to, use of, or reliance on this drawing. The customer acknowledges that the product is provided as-is and that the customer and/or the responsible local highway authority (the "Authority"), the professional judgement of the customer and/or the responsible local highway authority (the "Authority"), the product must be assembled and installed in a manner not inconsistent with the Procedures and must comply with federal, state and local standards. Installation and any modifications to the product should be reviewed and approved by the Authority.

NOTES: UNLESS OTHERWISE SPECIFIED.

1. ABSORB-M SYSTEM TO BE INSTALLED PER MANUFACTURER'S INSTRUCTIONS. SEE ASSEMBLY AND INSTALLATION MANUAL FOR ADDITIONAL DETAILS.
2. SAFEGE BARRIER TO BE INSTALLED PER MANUFACTURER'S INSTRUCTIONS.
3. ABSORB-M TO SAFEGE ADAPTER TO BE INSTALLED UTILIZING THE CONNECTING PINS AND HOLE ON THE SAFEGE BARRIER AND 1 AT THE TOP CONNECTION PLATE. \varnothing 22mm BOLT
4. ABSORB-M TRANSITION TO BUTT AGAINST THE ABSORB-M TO SAFEGE ADAPTER.
5. ABSORB-M STRAPS REQUIRE 2 HOLES MATCH DRILLED THROUGH THE SAFEGE BARRIER TO ACCOMMODATE \varnothing 5/8" [16mm] THREADED RODS. THREADED ROD TO BE SECURED WITH FLAT WASHERS & NUTS, THEN FIELD TRIMMED AS REQUIRED. THREADED ROD AND ATTACHMENT HARDWARE NOT INCLUDED IN ABSORB-M SYSTEM, TO BE PROVIDED BY OTHERS.
6. END SEGMENT OF SAFEGE BARRIER TO BE FULLY ANCHORED IN 8 LOCATIONS.
7. REMAINING SAFEGE BARRIER TO BE ANCHORED EVERY 11.6m PER MANUFACTURER'S INSTRUCTIONS FOR LIMITED DEFLECTION SYSTEMS.

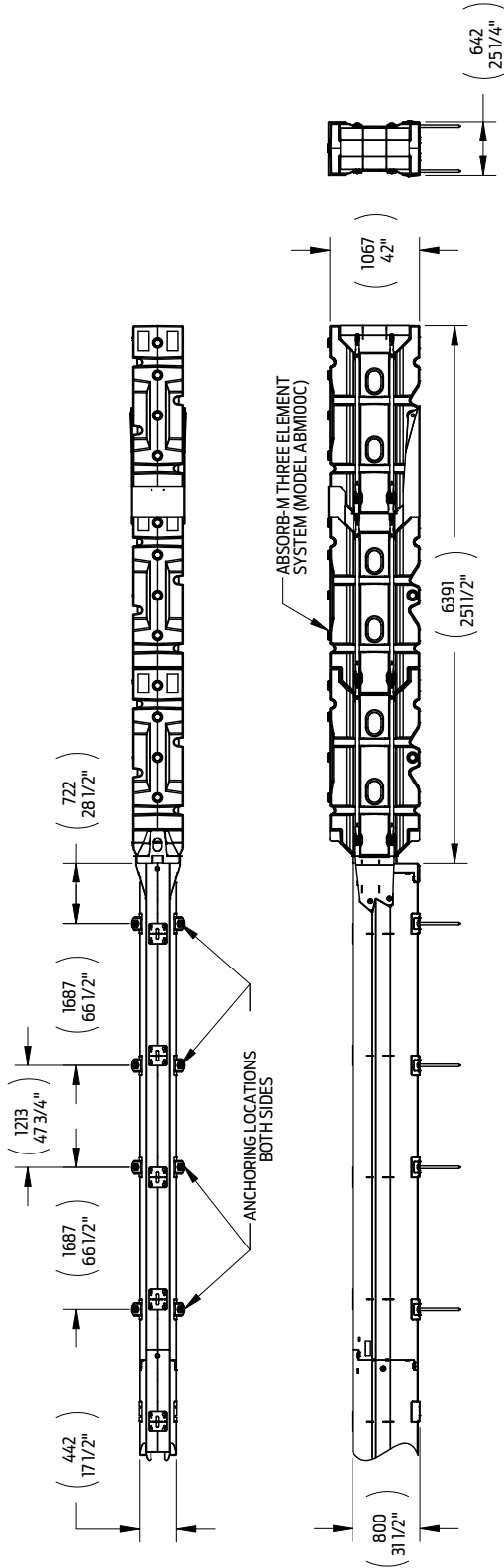

		Material: N/A DWGNO: BSI-2007024-AP	Revision	2
			Title: Absorb-m Transition To Safezone Barrier Limited Deflection Configuration Scale: 1:50 Size: B	
Date: 24-7-2020 Approved by: JMT	Date: 24-7-2020 Unit: mm	Drawn by: NBP Approved by: JMT		
Comments: This copyright of this drawing is reserved by us. It remains the property of the Jaybro Group and may not be reproduced or shown to third parties without permission.				
Jaybro Group Pty Ltd 20 Penelope Crescent, Arndell Park NSW 2148 TEL: 1300 885 364 www.jaybro.com.au				

Revision	Date	ECN#
1	24-07-2020	AP 01547
2	04-11-2020	AP 01547

The drawing is provided for informational purposes only and is based upon information provided to Jaybro by the customer (which may not reflect, among other things, certain information that could be obtained via an in-person visit to, or familiarity with, the installation site). Neither Jaybro nor any of its affiliates is liable for any direct, indirect, incidental, consequential, or punitive damages arising out of or related to the customer's access to, use of, or reliance on this drawing. The customer acknowledges that the use of this drawing is subject to the terms and conditions of the previously provided installation/assembly procedures (the "Procedures") and (2) the professional judgement of the customer and/or the responsible local highway authority (the "Authority"). The product must be assembled and installed in a manner not inconsistent with the Procedures and must comply with federal, state and local standards. Installation and any modifications to the product should be reviewed and approved by the Authority.

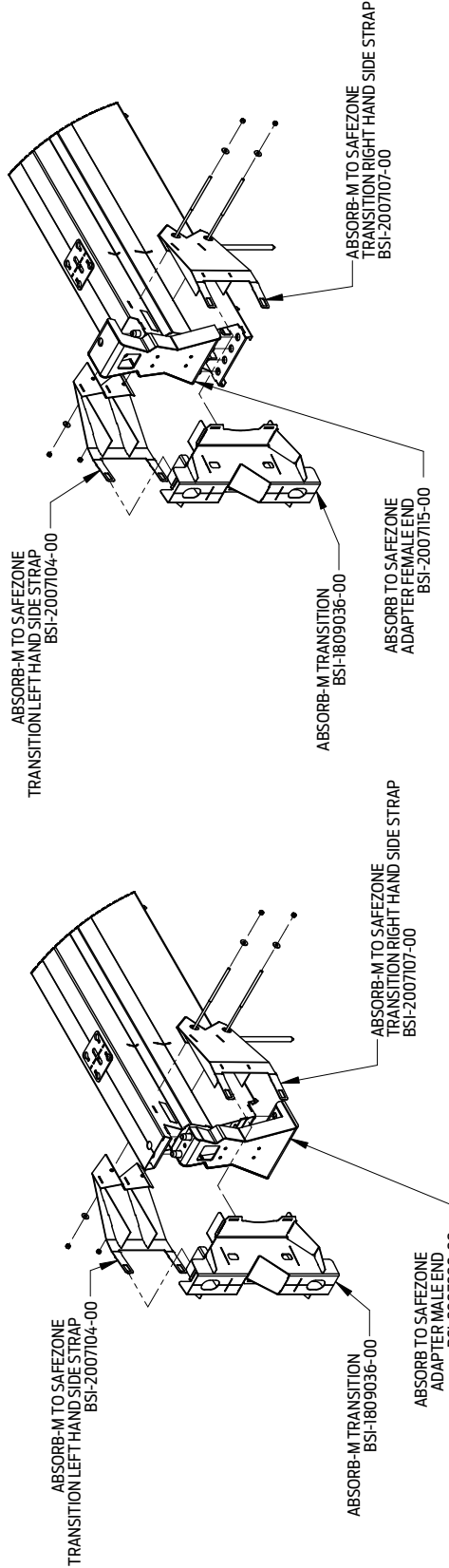

 SafeZone™ <small>safe zone - simpler, smarter, safer.</small>	DWG Number: B BSI-2007024-AP	Revision: 2
	Size: B	Sheet: 2 OF 2 Scale: 1:25
<small>The copyright of this drawing is reserved by us. It remains the property of the Jaybro Group and may not be reproduced or shown to third parties without permission.</small>		
<small>Jaybro Group Pty Ltd 29 Penelope Crescent, Armidale Park NSW 2348 TEL: 1300 885 364 www.jaybro.com.au</small>		

NOTES: UNLESS OTHERWISE SPECIFIED.

1. ABSORB-M SYSTEM TO BE INSTALLED PER MANUFACTURER'S INSTRUCTIONS. SEE ASSEMBLY AND INSTALLATION MANUAL FOR ADDITIONAL DETAILS.
2. SAFEGONE BARRIER TO BE INSTALLED PER MANUFACTURER'S INSTRUCTIONS.
3. ABSORB-M TO SAFEGONE ADAPTER TO BE INSTALLED UTILIZING THE CONNECTING PINS AND HOLE ON THE SAFEGONE BARRIER AND 1 \varnothing 22mm BOLT AT THE TOP CONNECTION PLATE.
4. ABSORB-M TRANSITION TO BUTT AGAINST THE ABSORB-M TO SAFEGONE ADAPTER.
5. ABSORB-M STRAPS REQUIRE 2 HOLES MATCH DRILLED THROUGH THE SAFEGONE BARRIER TO ACCOMMODATE \varnothing 5/8" [16mm] THREADED RODS. THREADED ROD TO BE SECURED WITH FLAT WASHERS & NUTS; THEN FIELD TRIMMED AS REQUIRED. THREADED ROD AND ATTACHMENT HARDWARE NOT INCLUDED IN ABSORB-M SYSTEM, TO BE PROVIDED BY OTHERS.
6. END SEGMENT OF SAFEGONE BARRIER TO BE FULLY ANCHORED IN 8 LOCATIONS.
7. REMAINING SAFEGONE BARRIER TO BE ANCHORED EVERY 69.6m PER MANUFACTURER'S INSTRUCTIONS FOR STANDARD DEFLECTION SYSTEMS.

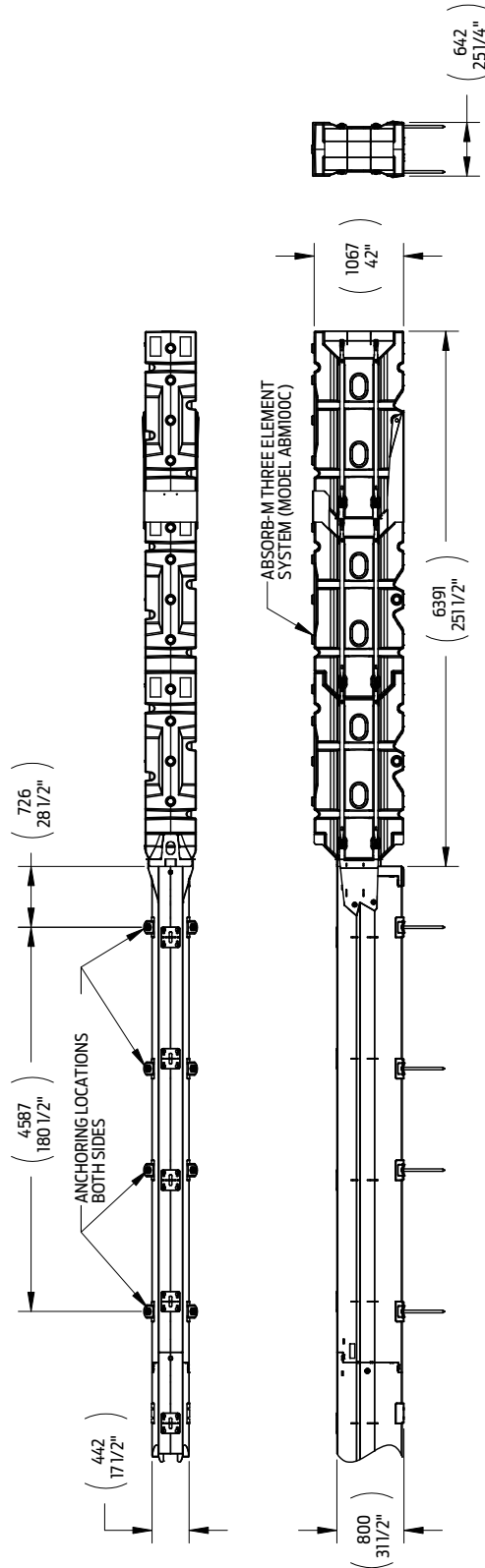

				Material: N/A
Date: 24-7-2020 Approved by: JMF		Date: 24-7-2020	DWG NO.: BSI-2007025-AP	Revision: 1
Drawn by: NBP		Unit: mm	Title: Absorb-m Transition To Safegone Barrier Standard Configuration	Scale: 1:50
Comments:		Site: B		
The copyright of this drawing is reserved by Jaybro. It remains the property of the Jaybro Group and may not be reproduced or shown to third parties without permission.				
Jaybro Group Pty Ltd 29 Penelope Crescent, Arndell Park NSW 2148 TEL: 1300 885 364 www.jaybro.com.au				

Revision	Date	ECN#
1	24-07-2020	AP 01547

This drawing is provided for informational purposes only and is based upon information provided to Jaybro by the customer (which may not reflect, among other things, certain information that could be obtained via an in-person visit to, or familiarity with, the installation site). Neither Jaybro nor any of its affiliates is liable for any direct, indirect, incidental, consequential, or punitive damages arising out of or related to the customer's access to, use of, or reliance on this drawing. Jaybro's liability is limited to the amount of the purchase price of the product previously provided installation/assembly procedures (the "Procedures") and (2) the professional judgement of the customer and/or the responsible local highway authority (the "Authority"). The product must be assembled and installed in a manner not inconsistent with the Procedures and must comply with federal, state and local standards. Installation and any modifications to the product should be reviewed and approved by the Authority.

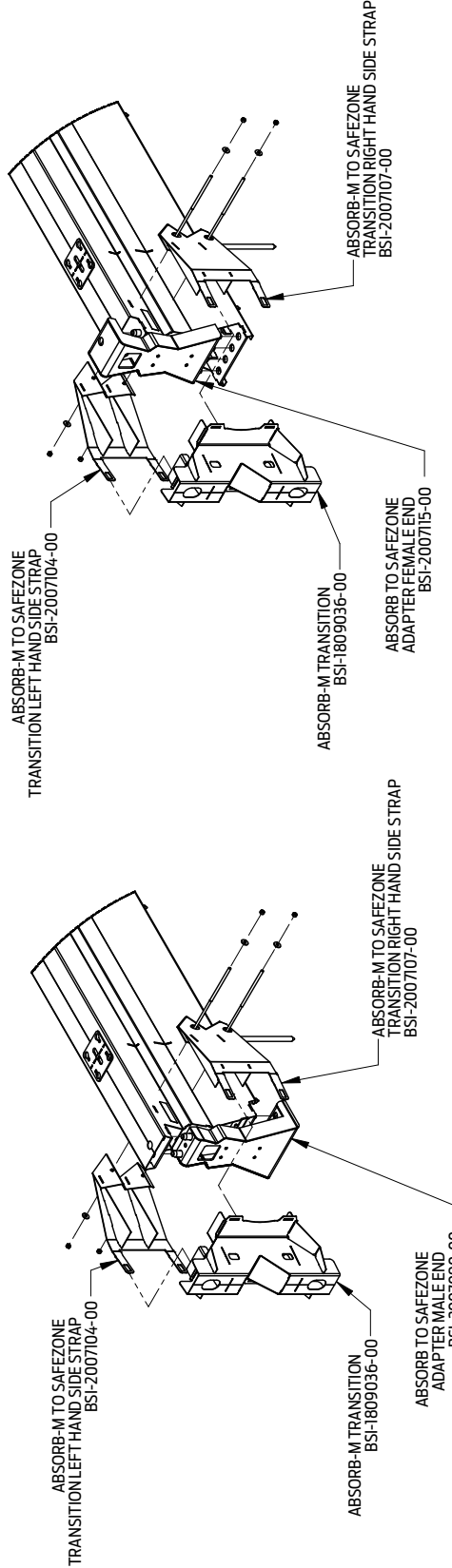

 SafeZone™ <small>safe · simpler · smarter</small>	Size	DWG Number	Revision
	B	BSI-2007025-AP	1
<small>The copyright of this drawing is reserved by us. It remains the property of the Jaybro Group and may not be reproduced or shown to third parties without permission.</small>			Scale
<small>Jaybro Group Pty Ltd 29 Penelope Crescent, Armidale Park NSW 2148 TEL: 1300 885 364 www.jaybro.com.au</small>			1:25

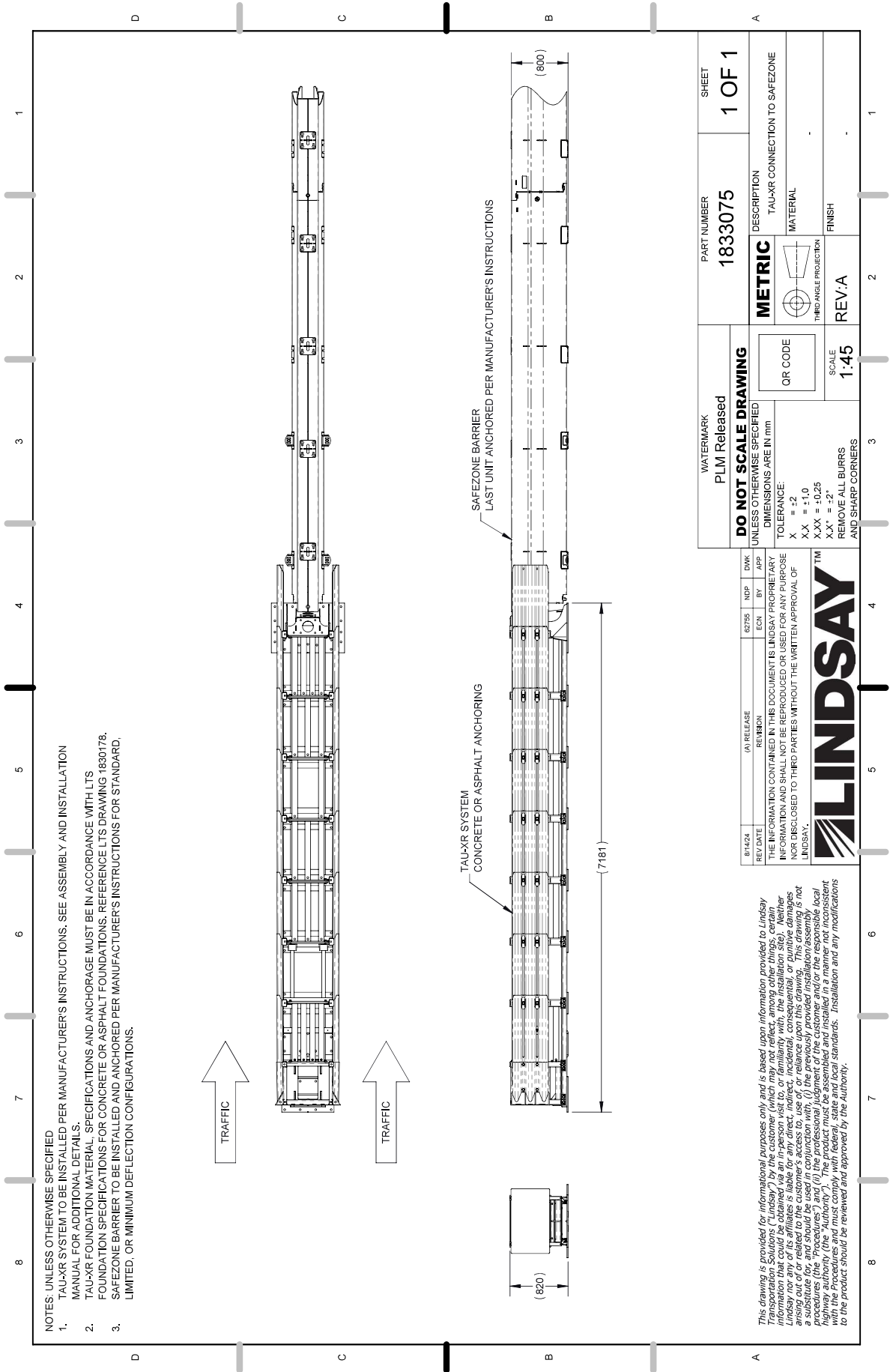

- NOTES: UNLESS OTHERWISE SPECIFIED
1. TAU-XR SYSTEM TO BE INSTALLED PER MANUFACTURER'S INSTRUCTIONS. SEE ASSEMBLY AND INSTALLATION MANUAL FOR ADDITIONAL DETAILS.
 2. TAU-XR FOUNDATION MATERIAL, SPECIFICATIONS AND ANCHORAGE MUST BE IN ACCORDANCE WITH ITS FOUNDATION SPECIFICATIONS FOR CONCRETE OR ASPHALT FOUNDATIONS. REFERENCE ITS DRAWING 1830178.
 3. SAFEZONE BARRIER TO BE INSTALLED AND ANCHORED PER MANUFACTURER'S INSTRUCTIONS FOR STANDARD, LIMITED, OR MINIMUM DEFLECTION CONFIGURATIONS.

WATERMARK PLM Released		PART NUMBER 1833075		SHEET 1 OF 1	
DO NOT SCALE DRAWING		DESCRIPTION TAU-XR CONNECTION TO SAFEZONE MATERIAL		FINISH REV-A	
UNLESS OTHERWISE SPECIFIED DIMENSIONS ARE IN mm		QR CODE		SCALE 1:45	
TOLERANCE: X = ±2 X.X = ±1.0 X.XX = ±0.25 X.X° = ±2°		REMOVE ALL BURRS AND SHARP CORNERS		FINISH	
(A) RELEASE REVISION		62755 NCP BY APP		THE INFORMATION CONTAINED IN THIS DOCUMENT IS LINDSAY PROPRIETARY INFORMATION AND SHALL NOT BE REPRODUCED OR USED FOR ANY PURPOSE NOR DISCLOSED TO THIRD PARTIES WITHOUT THE WRITTEN APPROVAL OF LINDSAY.	
REV DATE		62755 NCP BY APP			

This drawing is provided for informational purposes only and is based upon information provided to Lindsay Transportation Solutions ("Lindsay") by the customer (which may not reflect, among other things, certain details or conditions of the site or project). Lindsay and its affiliates are not responsible for any damages, incidental, consequential, or punitive damages arising out of or related to the customer's access to, use of, or reliance upon this drawing. This drawing is not a substitute for, and should be used in conjunction with, (i) the previously provided installation/assembly instructions for the product, (ii) the product manual, and (iii) the applicable federal, state, and local highway authority (the "Authority"). The product must be assembled and installed in a manner not inconsistent with the Procedures and must comply with federal, state and local standards. Installation and any modifications to the product should be reviewed and approved by the Authority.