

Product Data Sheet

RamShield® Low Deflection



SafeDirection
CRASH BARRIER SOLUTIONS

Last Updated: January 2025

Containment Level	MASH TL3
Impact Condition	2270 kg pick-up truck, 100km/h, 25°
Dynamic Deflection	1.1m without blocks 1.2m with RamBlocs™
Standard Post Spacing	2.0 m centres
System Height	800 mm
System Width	235 mm without blocks 385 mm with RamBlocs™
System Mass	23.5 kg per metre without blocks 26 kg per metre with RamBlocs™
System Finish	Hot dip galvanized
Post Length	1660 mm
Post Dimensions	150 x 110 x4.3 mm
Post Mass	21 kg
Installation Variants	The installation of RamBlocs™ is optional Posts with baseplates Attachment of BikerShield™ Motorcyclist Protection





Rail splices, mid-span between posts

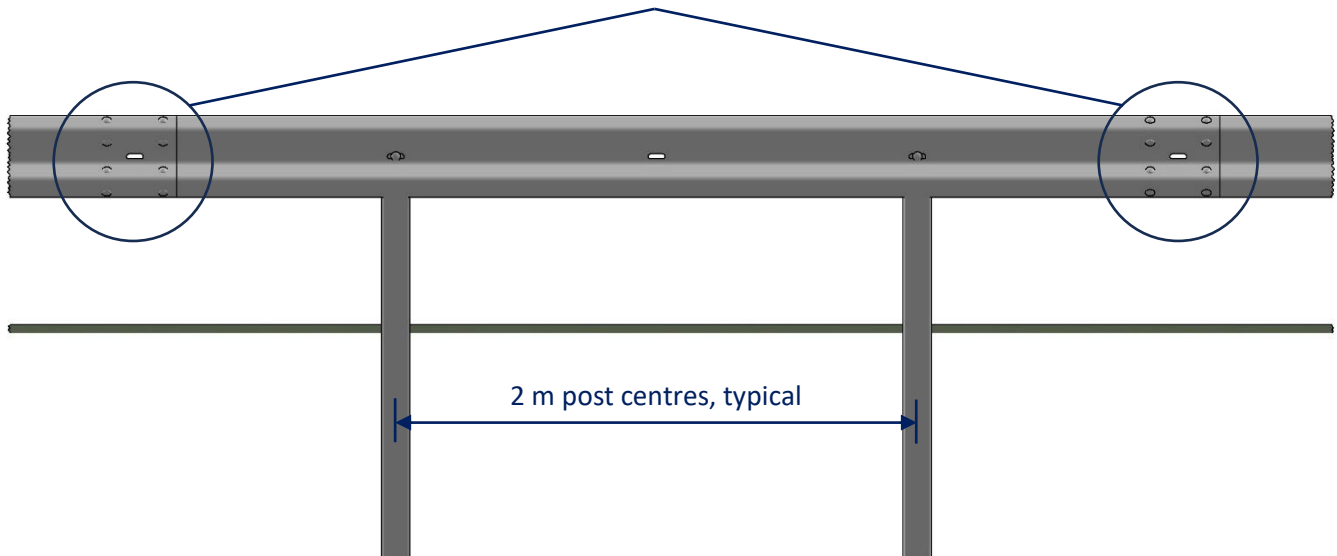

FRONT VIEW

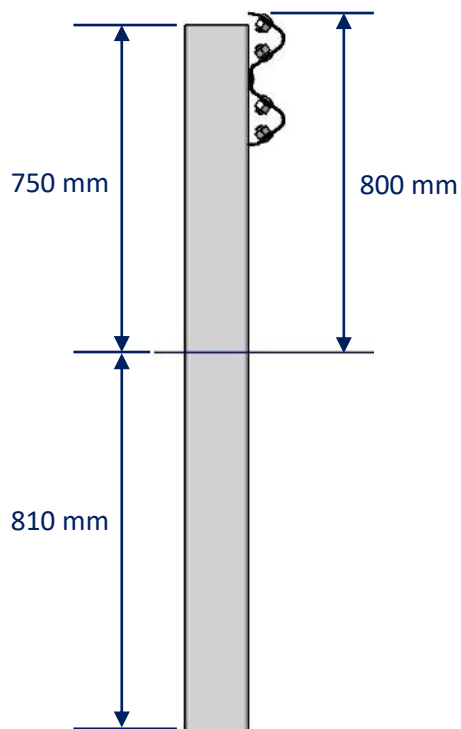

**SIDE ELEVATION
without blocks**

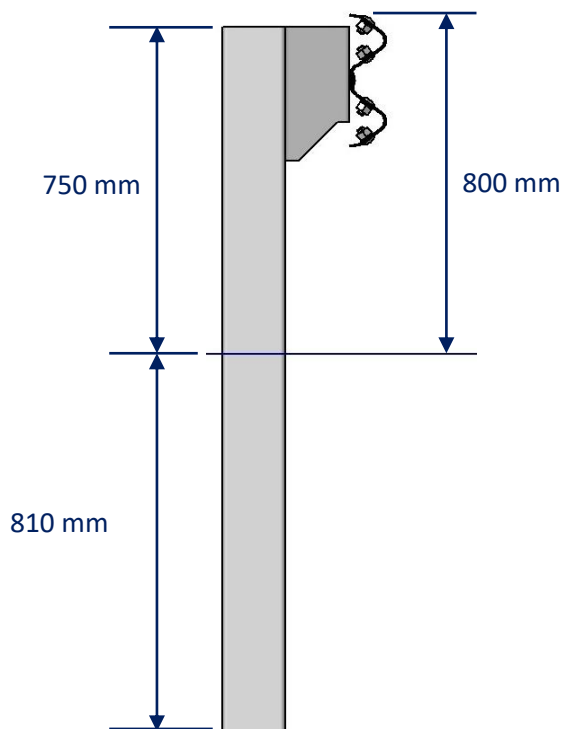

**SIDE ELEVATION
with RamBlocs™**