

RamShield[®] Low Deflection

MASH TL3 Compliant Barrier





Table of Contents

1.0	Introduction	5
2.0	Specifications	5
3.0	How RamShield® LD Works	5
4.0	Material Traceability	6
5.0	Crash Test Performance	7
6.0	Design Considerations	8
6.1	Installation without Blocks.....	8
6.2	Installation with RamBlocs®	8
6.3	Advance Grading.....	9
6.4	Clearance to Hazards.....	9
6.5	Adjacent to a Batter Slope	9
6.6	The Shy Line Offset.....	10
6.7	Flaring.....	10
6.8	System Installed Height.....	10
6.9	Placement in Rock or Deep Asphalt	11
6.10	Minimum Installation Length	11
6.11	Kerbs	12
6.12	End Terminals.....	13
6.13	The Point-of-Need.....	13
6.14	Transitioning to a Rigid Barrier.....	14
6.15	Connection to RamShield® HC.....	15
6.16	Connection to RamShield® W-Beam	15
6.17	BikerShield™ Motorcycle Barrier	16
6.18	Posts on Baseplates.....	17
6.19	Installation on Curves	19
6.20	Design Life.....	20
7.0	Component Identification	21
8.0	Tools Required	22
8.1	Recommended PPE	22
9.0	Site Establishment	22
9.1	Traffic Control.....	22
9.2	Underground Services	22



9.3 Overhead Obstructions..... 22

9.4 Unloading Exclusion Zone 22

10.0 Installation Sequence 23

11.0 Set-Out 23

12.0 Post Installation 24

13.0 Attaching RamBlocs® 24

14.0 Attaching the W-Beam Rails..... 24

15.0 Recommended Tolerances 25

RamShield® LD Inspection Form..... 26

16.0 Maintenance 27

17.0 Dismantling..... 27

17.1 Removing the W-Beam Rails..... 27

17.2 Removing the RamBlocs® 27

17.3 Removing the C-Posts 27

18.0 Repair..... 28

18.1 Removal of Damaged Posts..... 28

18.2 Removal of Damaged Rails..... 28





Leading Safety

Successfully crash tested to MASH Test Level 3

Complies with AS/NZS 3845.1:2015 Road safety barrier systems and devices

Superior Design

Simple rail to post assembly

Available with the RamBloc[®], providing an offset between the w-beam rail and C-post

Same C-post profile as used in public domain systems

Reduced post embedment depth when compared with public domain systems

Rails splices positioned mid-span between posts

Low Deflection

Shields roadside hazards close to the travelled way

Stable containment and redirection

Reduced distance between the barrier and a fixed hazard

Compatibility

Features standard w-beam manufactured by Safe Direction

Compatible with the MSKT guardrail end terminal

Standard 2m post spacing

Fast Assembly

Fewer parts

Stiff driving C-post



1.0 Introduction

RamShield® Low Deflection is the latest innovation and advancement in w-beam guardrail barrier designs. Developed by Safe Direction, RamShield® Low Deflection has been full-scale crash tested to MASH Test Level 3.

Providing a forgiving roadside environment reduces the consequences for vehicles leaving the safe, travelled way. Hazards such as trees, utility poles, culverts and embankments are often located adjacent to roadways and relocating them is often impractical. In these instances, shielding with a longitudinal safety barrier, such as RamShield® Low Deflection is the most appropriate solution.

W-beam barrier designs have developed over the years and are used to safely contain and re-direct errant vehicles away from nearby hazards. Safety barriers reduce the severity of run-off-the-road crashes and have made a significant contribution to the safety of our region’s roads.

RamShield® Low Deflection reduces the clearance required between barrier and hazard, an important design consideration for installation on narrow formations.

2.0 Specifications

Compliance:	MASH Test Level 3
	AS/NZS 3845.1:2015
Standard C-post length:	1660mm
C-post mass:	21kg
C-post section:	150 x 110 x 4.3mm
Standard C-post spacing:	2.0m centres
System height:	800mm
System finish:	Hot dip galvanised to AS/NZS 4680

3.0 How RamShield® LD Works

RamShield® Low Deflection achieves a controlled redirection of errant vehicles by regulating the force to release the rail throughout the impact zone, limiting dynamic deflection and to allow the C-post to collapse without tripping the vehicle.

The separation of the w-beam rail during a vehicle collision is achieved by a release tab. This allows the rail to be disengaged at an optimal load, facilitating safe vehicle containment and redirection.

RamShield® Low Deflection uses standard w-beam guardrail and standard fasteners meaning there is very little risk of inadvertent use of non-compliant items. The w-beam rails are spliced mid-span between C-posts, facilitating ease of access during installation.

RamShield® Low Deflection features C-posts designed to collapse upon impact, yielding proximate to the ground following the controlled release of the rail. This release and collapse mechanism makes the RamShield® Low Deflection C-post suitable for use in stiff soils and deep asphalt applications.

The sectional strength of the C-post limits barrier deflection, an important design consideration for shielding roadside hazards and steep embankments located within close proximity to the edge of the travelled way.

The working mechanism of RamShield® Low Deflection is a patented concept designed and developed by Safe Direction. The concept is the latest innovation in guardrail design and sets a new benchmark in simplicity and performance

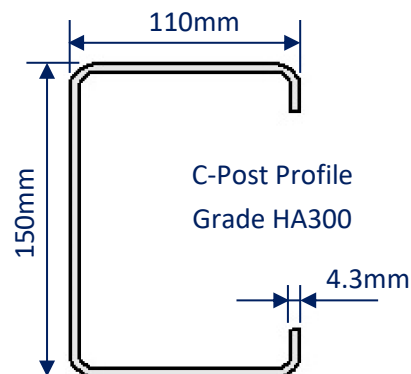



4.0 Material Traceability

Safe Direction operates a quality management system, independently certified to the requirements of ISO 9001:2015.

A multi-stepped procedure is used by Safe Direction to verify the compliance of the material used in the production of RamShield® Low Deflection posts and w-beam guardrail to AS/NZS 1594.

Mill certificates and independent third-party laboratory test results are verified against Australian Standard guidelines recording the steel heat numbers, mechanical results and chemical composition.

Safe Direction product is then stamped during manufacture with a 4-digit number providing industry-leading traceability to the steel heat number. The format for stamping w-beam guardrails is:

Example: SD 9419 350 27

Where: SD = product from Safe Direction
 9419 = the last 4 digits of the heat no.
 350 = steel grade (i.e. HA 350)
 27 = base metal thickness (i.e 2.7mm)



TEST CERTIFICATE													
CHEMICAL ANALYSIS													
Percentage of element by mass (L=Cast, P=Product, -S=Soluble, -T=Total, CF=Chemical Formula, n=Min, x=Max)													
Item No	Heat / Unit No	NATA Lab	L/P	C	P	Mn	Si	S	Ni	Cr	Mo	Cu	Al-T
0010	6709419	0632	L	.157	.019	.74	<.005	.015	.016	.035	.004	.042	.034
Item No	Heat / Unit No	NATA Lab	L/P	Ti	B-T	N	Nb	Sn	V	CF1	CF2	CF3	
0010	6709419	0632	L	<.002	<.0003	.0045	.001	.002	<.003	.29	.10	.00	
CF1=C+ (MN/6) + ((CR+MO+V)/5) + ((CU+NI)/15) CF2=NI + CR + CU + MO CF3=NB + TI + V													
MECHANICAL TESTING													
Tensile AS 1391													
Item No	Heat No	Tested Unit	NATA Lab	Cat	Loc	THICK mm	ReH MPa	Rm MPa	Lo mm	ELONGN %			
0010	6709419	1H1F9690	0631	B	LQF	2.70	420	520	80	25			
0010	6709419	1H1F9845	0631	B	LQF	2.70	390	500	80	22			
ITEMS COVERED BY THIS CERTIFICATE													
Item No	Heat No	Ordered Dimensions (mm)	No of Units	Mass (Tonnes)	Unit Identities								
0010	6709419	740.0X2.70XCOIL	6	24.030	1H1H9291AA 1H1H9291BA 1H1H9291CA 1H1H9291DA 1H1H9292AA 1H1H9292CA								



5.0 Crash Test Performance

RamShield® Low Deflection has been fully crash tested and evaluated according to the specifications for Test Level 3 (TL3) of the AASHTO Manual for Assessing Safety Hardware (MASH). The MASH specification is an update to and supersedes NCHRP Report 350 for the purposes of evaluating new safety hardware devices.

MASH is also the basis of testing procedures for road safety systems as stated in *AS/NZS 3845.1: 2015 Road Safety Barrier System and Devices*.

The MASH TL3 crash test matrix requires the following impacts:

- 2270kg pick-up travelling at 100km/h and 25°.
- 1100kg car travelling at 100km/h and 25°.

RamShield® Low Deflection has been crash tested with direct connection of the w-beam guardrail to the C-post and with RamBlocs®, providing a 150mm offset between the w-beam rail and post.

Table 1: MASH TL3 Deflections

Barrier Configuration	MASH TL3 Deflection
RamShield® Low Deflection, rail connected directly to C-posts	1.1m
RamShield® Low Deflection, with RamBlocs®	1.2m



Figure 1: Full-Scale Crash Testing of RamShield® Low Deflection with RamBlocs®.

6.0 Design Considerations

6.1 Installation without Blocks

RamShield® Low Deflection may be installed with the w-beam rail connected directly to the C-post, reducing the width of the system. This is an important design consideration for sites with a narrow formation.

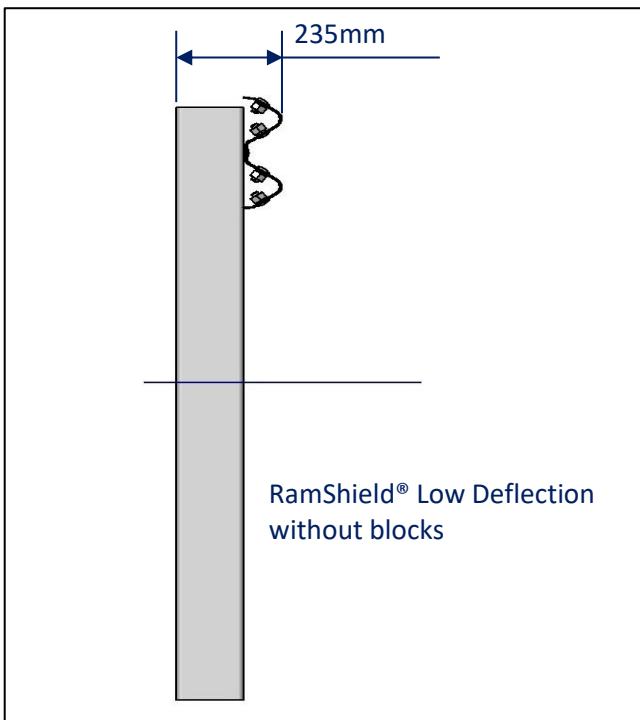

Figure 2: RamShield® Low Deflection without Blocks

6.2 Installation with RamBlocs®

RamShield® Low Deflection may be installed with the RamBloc®, a 150mm steel RHS spacer positioned between the C-post and w-beam guardrail. The RamBloc® allows the face of rail to be offset from the C-post, an important design consideration when accommodating the alignment of drainage or asphalt beneath the barrier system.

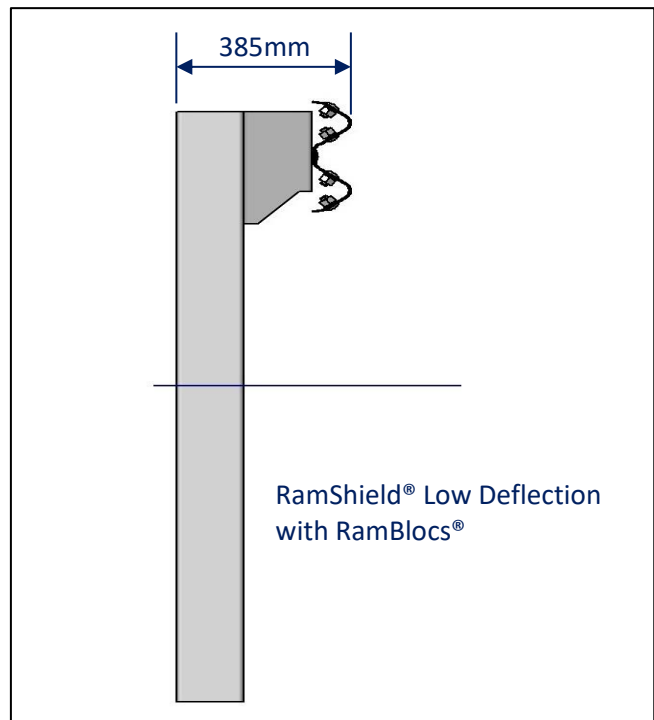

Figure 3: RamShield® Low Deflection with RamBlocs®



6.3 Advance Grading

It is recommended that the area in advance of RamShield® Low Deflection be limited to a grading of 10H:1V to ensure that the vehicle's suspension is neither extended nor compressed at the moment of impact with the barrier.

6.4 Clearance to Hazards

The system should be installed with sufficient clearance behind the barrier to allow for the expected deflection of the system.

Dynamic deflection is the maximum lateral displacement of the barrier during a vehicle impact. When a vehicle strikes a barrier, the dynamic deflection varies according to the characteristics of the impacting vehicle, including vehicle mass, impact speed, angle of impact and the characteristics of the barrier system.

The MASH TL3 impact condition (2270kg pick-up truck travelling at 100km/h and 25 degrees) has been developed to represent 'worst case impact scenario'.

Please consult with Safe Direction for expected barrier deflection at varying vehicle speeds and impact angles.

6.5 Adjacent to a Batter Slope

Space in the road corridor is premium. In an effort to maximise space for other infrastructure and landscaping, the proximity of the guardrail post to the batter hinge point is often reduced without evidence or justification through crash testing.

Best practice ensures that the vehicle remains on the verge, that there is no damage to the batter following an impact and that the embankment provides adequate support to resist the impact loads.

State Road Agency guidelines typically require the distance to the hinge point be sufficient to accommodate the barrier's design deflection and provide adequate lateral support for the system.

Positioning the barrier closer to the hinge point:

- Increases the risk of the barrier failing if its lateral support is insufficient.
- Reduces the ease for maintenance crews to inspect and reconstruct the barrier.
- Increases the risk that the vehicle will become unstable on the shoulder, or has a more unstable redirection; and
- Increases the possibility that the embankment slope will be damaged on impact and will be more difficult to repair.

However, moving the barrier closer to the road:

- Increases the potential for high-frequency impacts with the barrier.
- Reduces road shoulder width; and
- Increases centreline crowding and risk of head-on collision.

Therefore, on constrained sites, the barrier may be required to be positioned near or at the batter hinge point. At these locations, industry practice has been to install longer posts providing increased embedment depth and improved barrier lateral support.

Safe Direction has undertaken dynamic load impacts of the RamShield® Low Deflection C-post when installed adjacent to a weak soil embankment, studying the effects of increasing post embedment depth and comparing post yielding behaviour with flat terrain performance.

Please contact Safe Direction for guidance and recommendations for constrained site installations.



6.6 The Shy Line Offset

Drivers tend to reduce speed or laterally move their vehicles away from a road safety barrier if it is within close proximity to the edge of the travelled way.

The distance from the edge of the travelled way beyond which a safety barrier will not be perceived as an immediate hazard by the typical driver is known as the shy line offset. Recommendations for the shy line offset are contained in Table 2.

Table 2: Shy Line Offset

Design Speed (km/h)	Shy Line Offset (m)
50	1.1
60	1.4
70	1.7
80	2.0
90	2.2
100	2.4
110	2.8

Source: Austroads Design Guide 5.4

6.7 Flaring

Motorists are less likely to perceive roadside barriers to be a hazard if the barrier is introduced gradually to the roadside environment through the use of a ‘flare’. The flare rate is the ratio of the length of the flared part of the barrier (measured parallel to the road) to the barrier offset.

Flaring the safety barrier system provides the following benefits:

- The end terminals can be positioned further from the travelled path reducing the potential for a head-on impact.
- The shy line effects where a hazard is close to the travelled path is minimised.
- Flaring provides a gradual transition to a major hazard close to the roadway (such as a bridge parapet or railing).

The maximum flare rates that should be used on an approach to a road safety barrier are shown in Table 3. Following the guidelines of Table 3 ensures that the flare does not significantly increase the opportunity for high-angle impacts with the barrier.

Table 3: Flare Rate

Design Speed (km/h)	Flare Rate (within Shy Line Offset)	Flare Rate (outside Shy Line Offset)
50	13:1	7:1
60	16:1	8:1
70	18:1	10:1
80	21:1	11:1
90	24:1	12:1
100	26:1	14:1
110	30:1	15:1

Source: Austroads Design Guide Table 5.5

The flare rate for end terminals may vary from those contained in Table 3. Please refer to specific Product Manual for allowable flare rates for end terminals.

6.8 System Installed Height

RamShield® Low Deflection has been crash tested at a rail height of 800mm ± 20mm above ground level providing compatibility with MASH compliant end terminals, including the MSKT.



6.9 Placement in Rock or Deep Asphalt

The rail release mechanism and performance of RamShield® Low Deflection differs from traditional barrier designs. Traditional posts will absorb some crash energy through post rotation in the surrounding soil prior to fully yielding. Setting these posts in deep lift asphalt or rock may compromise the performance of the system.

The patented RamShield® tab regulates the forces required to release the w-beam rail during a vehicle collision. The RamShield® Low Deflection C-post will typically yield by bending proximate to ground level.

Restraining the RamShield® Low Deflection C-post below ground level does not adversely affect the rail release mechanism.

Therefore, acceptable foundation pavement conditions for the installation of the RamShield® Low Deflection C-post includes the following:

- Narrow holes drilled into rock.
- Deep lift asphaltic concrete.
- Asphaltic concrete over granular pavement.
- Flush seal over granular pavement.
- Unsealed compacted formation.

Please consult with Safe Direction when rock is encountered, and full post embedment depth cannot be achieved.

6.10 Minimum Installation Length

The crash tested lengths of RamShield® Low Deflection are not meant to reflect minimum installation lengths. It is a requirement under the MASH standard to crash test installation lengths that minimise the influence of the end terminal in providing safe containment and redirection. This is regarded as 'worst case impact scenario'.

MASH compliant end terminals, such as the MSKT are evaluated for re-directional impacts with a 2270kg pick-up travelling at 100km/h and 25 degrees. The MSKT demonstrated safe vehicle containment and redirection within the terminal section. Therefore, a minimum installation for a constrained site may comprise back-to-back guardrail terminals.

It is recommended, where space permits, to install continuous safety barrier rather than designing a barrier to shield a specific hazard. A continuous safety barrier aims to protect the entire roadside and prevent vehicles rolling, impacts with hazards or head-on collisions.



6.11 Kerbs

Crash testing is typically performed on level terrain. Whilst it is preferable that in-service installations replicate crash test conditions, it is often necessary to provide kerbing to facilitate drainage.

The installation of barriers behind kerbs may affect the vehicle trajectory and safe containment and redirection.

Current guidelines for installation behind kerbs have been developed through bumper trajectory analysis. This analysis may not thoroughly evaluate vehicle and barrier interaction including vehicle stability through the course of the impact and the potential for vehicles to under-ride or over-ride the barrier system.

Safe Direction has performed a series of MASH TL3 simulated impacts on RamShield® variants installed immediately behind a mountable SF kerb. The SF kerb is widely used on the NSW classified road network and is regarded as the steepest of the mountable kerb types used throughout Australia thereby representing ‘worst practical condition’ to evaluate the potential for vehicle launching.

Two (2) W-Beam configurations were evaluated for each vehicle type:

1. Measuring the 800mm height of w-beam rail from road level; and
2. Measuring the 800mm height of w-beam rail from top of kerb.

The results of the 2270kg pick-up truck impacts (MASH 3-11) demonstrated improved vehicle stability during containment and redirection when measuring the 800mm height of w-beam rail from top of kerb.

Therefore, Safe Direction recommends measuring the system height of all RamShield® w-beam variants from top of kerb, regardless of the barrier offset behind the kerb as shown in Figure 4.

This methodology also ensures that the end terminals, which often feature posts with frangible connections, are correctly installed with the post hinge positioned at the ground line.

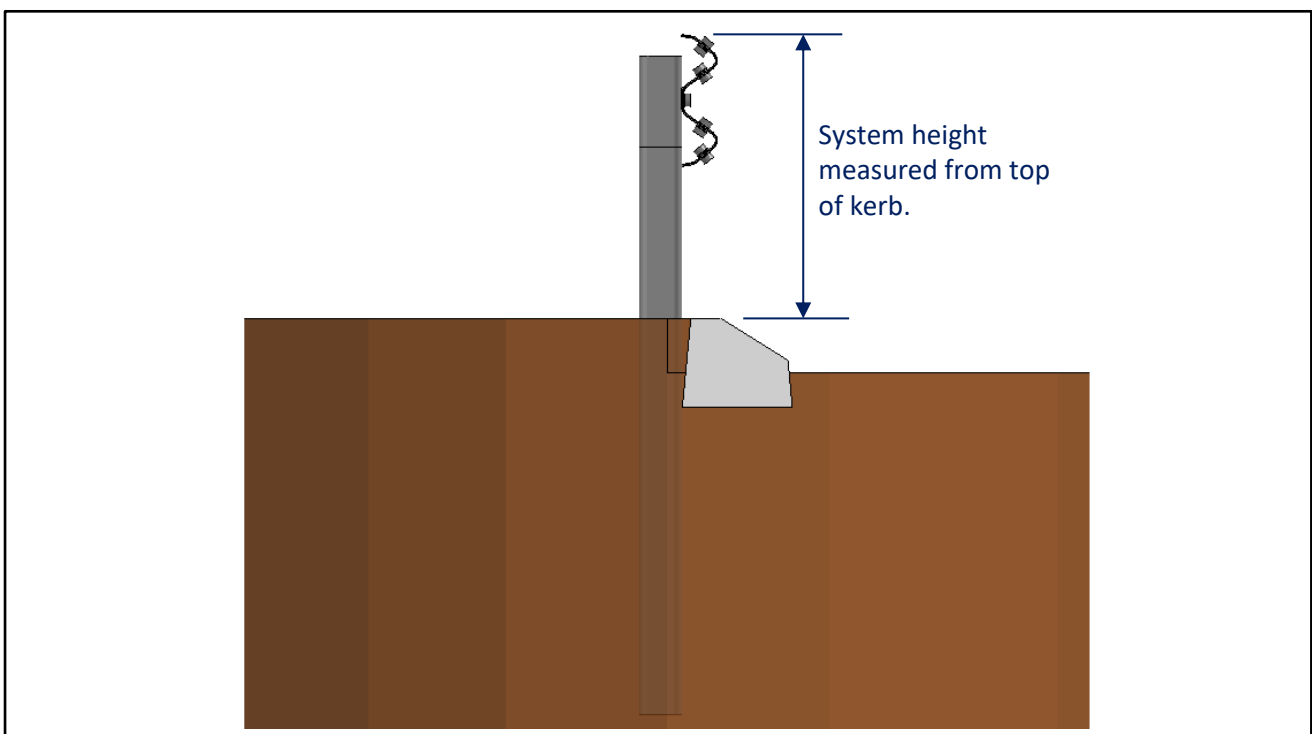

Figure 4: RamShield® Installation Behind a Mountable Kerb.

6.12 End Terminals

End terminals are designed to anchor the w-beam guardrail system and introduce the necessary tensile and flexural strength required for safe vehicle containment and re-direction throughout the length-of-need section.

Some guardrail end terminals also provide the additional feature of reducing the severity of an impact near or at the end of the system.

It is recommended that RamShield® Low Deflection be anchored at the leading and trailing end of the installation with MASH compliant end terminals, such as the MSKT.

The MSKT is an energy-absorbing tangential end terminal, designed to minimise the severity of impacts occurring at the end of the safety barrier system.

6.13 The Point-of-Need

RamShield® Low Deflection is designed to safely contain and re-direct errant vehicles away from roadside hazards. The point-of-need is the location where the barrier system becomes re-directive.

The point-of-need is typically dependent upon the end terminal selected to anchor the RamShield® Low Deflection system.

The point-of-need of a MSKT terminal is post location 3, a distance of 3.81m downstream from the start of the terminal.



Figure 5: MSKT Terminal Connection to RamShield® Low Deflection



6.14 Transitioning to a Rigid Barrier

Wherever it is necessary to change from one type of barrier to another, or to physically join them together (e.g. a bridge barrier to a road barrier), the interface must be designed to ensure that the overall system will perform safely when impacted by a design vehicle.

The RamShield® Transition provides a smooth, snag-free connection between w-beam and rigid barriers, such as at bridge parapets.

The RamShield® Transition gradually increases stiffness of the system reducing the potential for vehicle pocketing.

The RamShield® Transition has been fully crash tested and evaluated according to the specifications for MASH Test Level 3 and features thrie-beam guardrail with C-posts at reduced post spacings.

Connection of the RamShield® Transition to RamShield® Low Deflection is achieved using an asymmetric transition which increases the rail height from 800mm to 1000mm.



Figure 6: RamShield® Transition.

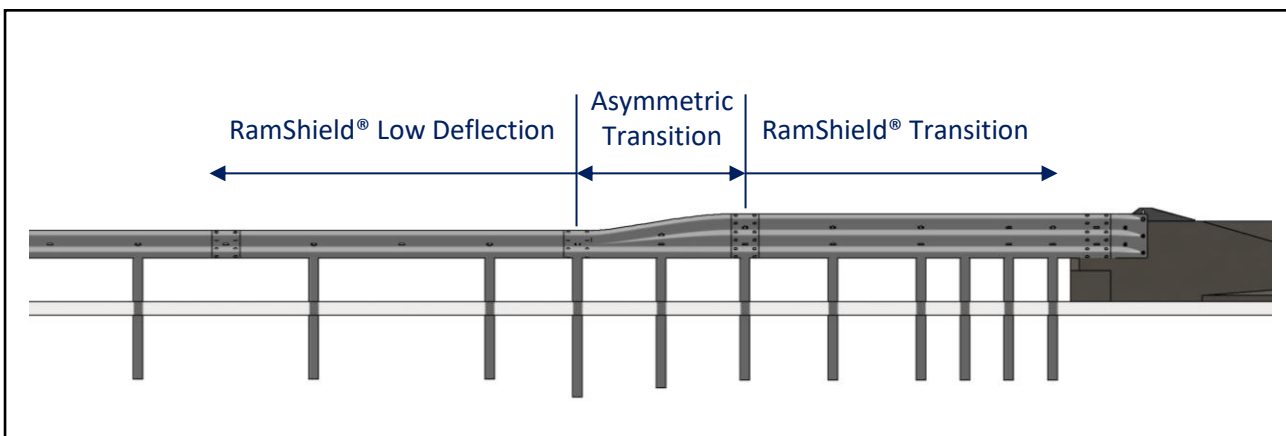

Figure 7: RamShield® Low Deflection, Connection to the RamShield® Transition.

6.15 Connection to RamShield® HC

RamShield® High Containment (HC) is a MASH TL4 compliant barrier featuring thrie-beam guardrail supported by C-posts.

The use of an asymmetric transition is required to transition from thrie-beam to w-beam guardrail. The asymmetric transition panel is 1905mm long (nett laying length) and is available as an approach or departure configuration (viewed from the road centreline).

The asymmetric transition increases the height to top of the rail by 200mm. RamShield® HC posts are installed at each end of the asymmetric transition as shown in Figure 6.

Note: The 1905mm (6'3") nett laying length of the asymmetric transition differs from the standard 2m post spacing of RamShield® Low Deflection.

6.16 Connection to RamShield® W-Beam

At sites where an isolated hazard is located within close proximity to the edge of the travelled way, RamShield® Low Deflection may be used in conjunction with RamShield® W-Beam to stiffen the barrier system in advance and adjacent to the hazard.

It is recommended that the installation of RamShield® Low Deflection commences 10m upstream of the hazard requiring shielding. If the roadway is undivided, the installation of RamShield® Low Deflection should also extend 10m downstream of the hazard.

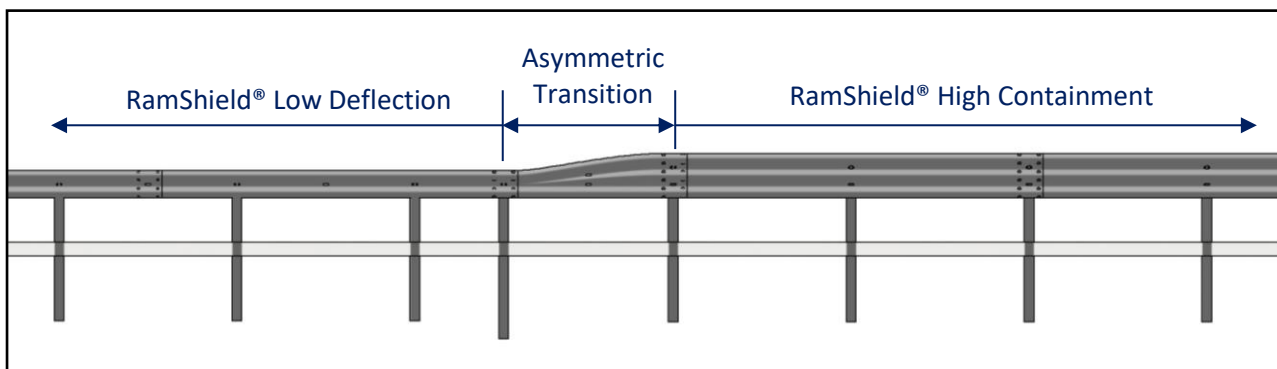

Figure 8: RamShield® Low Deflection, Connection to RamShield® HC.

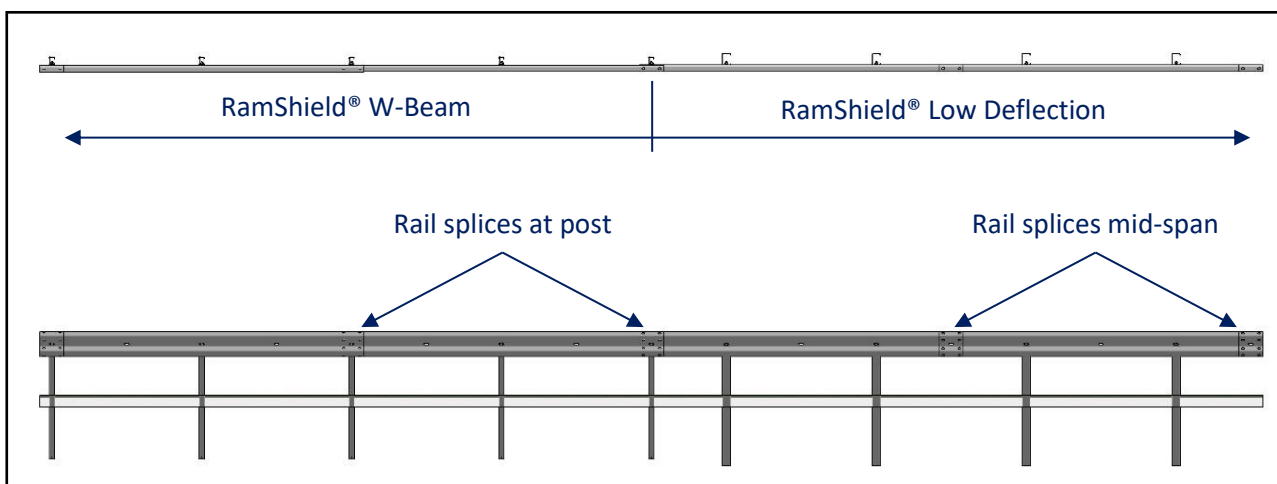

Figure 9: RamShield® Low Deflection, Connection to RamShield® W-Beam.

6.17 BikerShield™ Motorcycle Barrier

BikerShield™ is a motorcyclist safety barrier system designed to reduce the impact severity for riders when colliding with a roadside w-beam guardrail barrier.

BikerShield™ is positioned below the w-beam guardrail panel and prevents a dismounted motorcyclist from contacting the supporting posts of the guardrail barrier.

BikerShield™ provides safe rider containment and redirection through the combination of spring mounting brackets and lightweight, corrugated beams. The spring brackets attach directly to the w-beam guardrail mid-span between posts and absorb the impact energy of the sliding rider.

The position of BikerShield™ beneath the w-beam guardrail prevents rider contact with the posts and provides forgiving containment and redirection.

The attachment of the BikerShield™ mounting bracket to the guardrail beam ensures the BikerShield™ panel and beam will always vertically align independent of guardrail post geometry and offset distance between the post and beam.

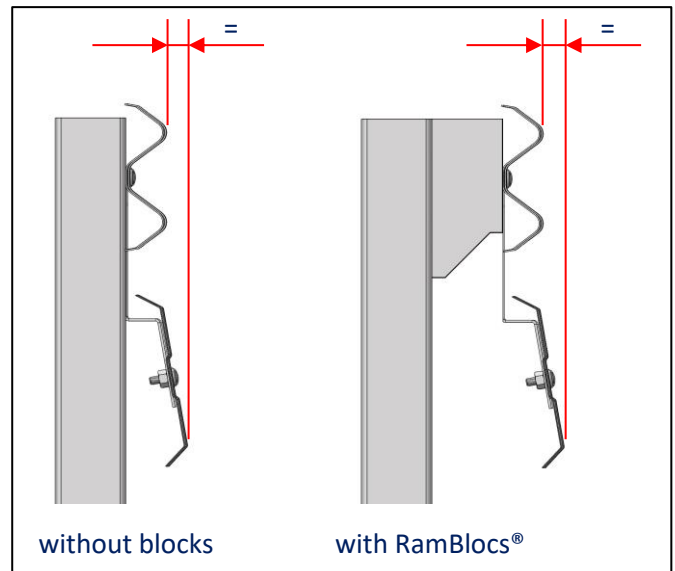

Figure 10: Vertical Alignment of BikerShield™

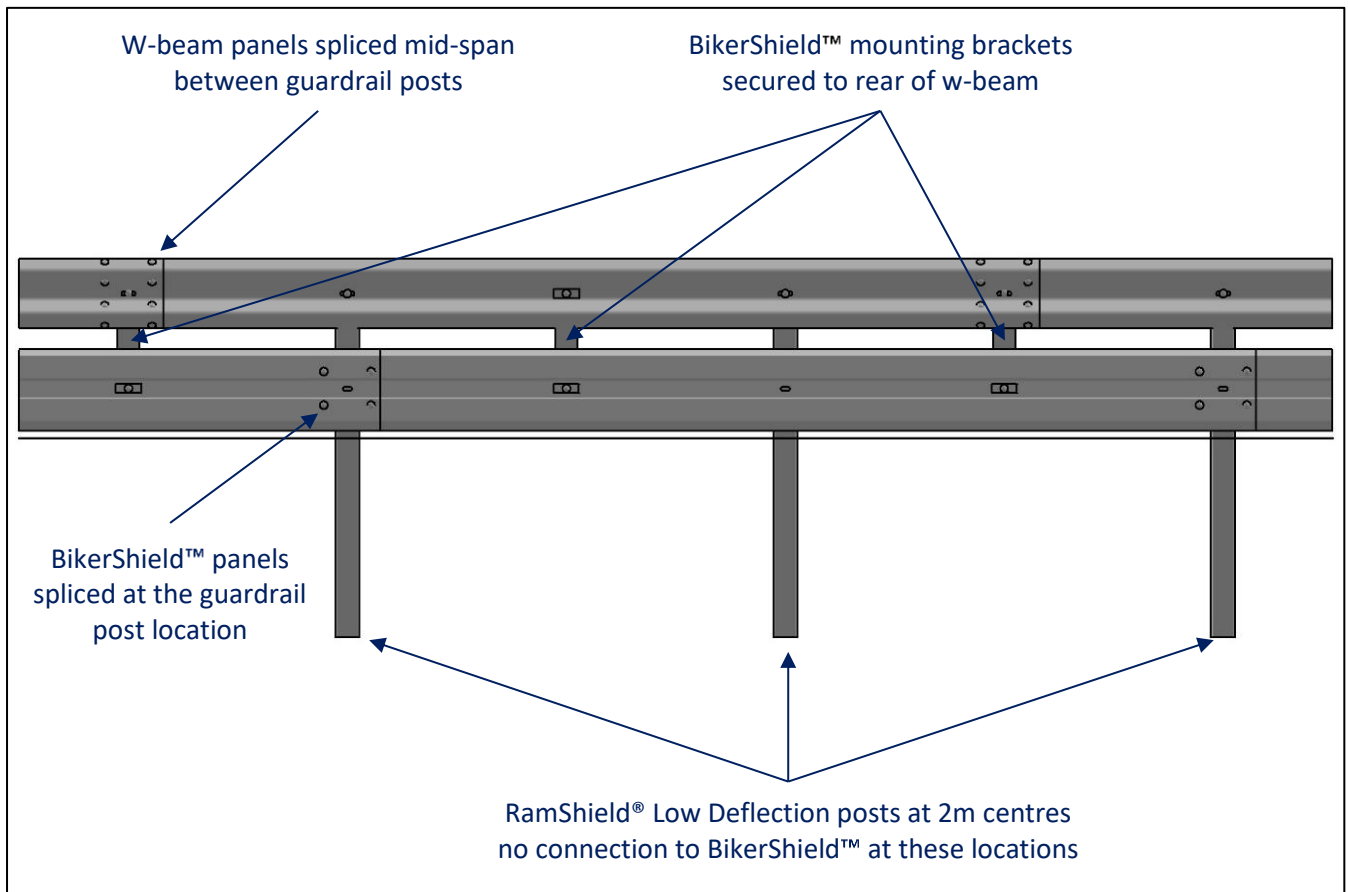

Figure 11: Attachment of BikerShield™ to RamShield® Low Deflection - Front View

6.18 Posts on Baseplates

Underground services and/or structures such as culverts may prevent RamShield® Low Deflection from being installed with posts driven into the ground. In these circumstances RamShield® Low Deflection may be installed with posts on baseplates secured to a concrete strip footing.

The RamShield® Low Deflection concrete footing was modelled with no soil behind the beam and therefore relies upon the beam mass to resist movement and overturning forces. This concept provides an important differentiation from footing designs that rely upon soil resistance since onsite soil properties are often unknown.

In addition, the RamShield® Low Deflection concrete footing has been assessed with posts positioned at the front and rear of the beam. This methodology assesses the maximum applied overturning moments, shear loads and uplift forces acting on the concrete beam and provides designers with a working tolerance range for the positioning of the posts.

The safe vehicle containment of the simulated impacts demonstrates appropriate footing and beam mass. Safe Direction provides various footing size options providing equivalent beam mass as adopted for the simulation impacts. In addition, mechanical or chemical anchor options are provided. Please refer to Safe Direction drawings.

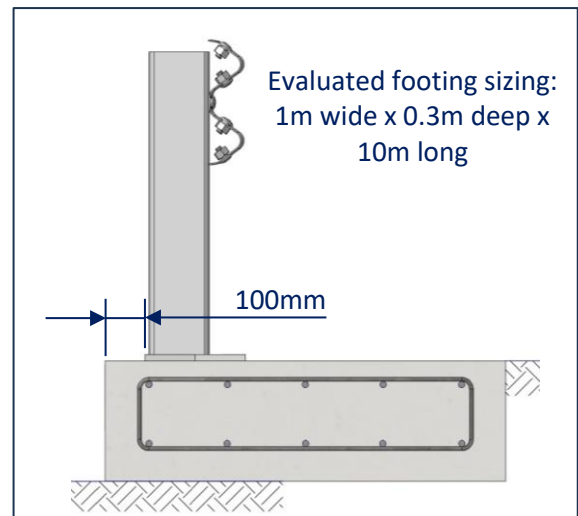

Figure 12: Post Evaluated at Rear of Footing

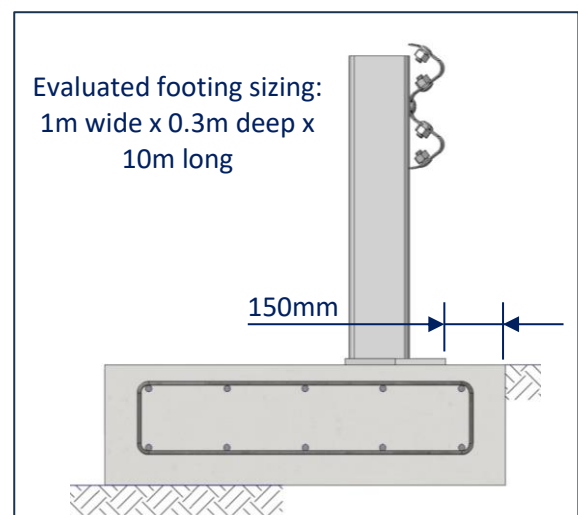

Figure 13: Post Evaluated at Front of Footing

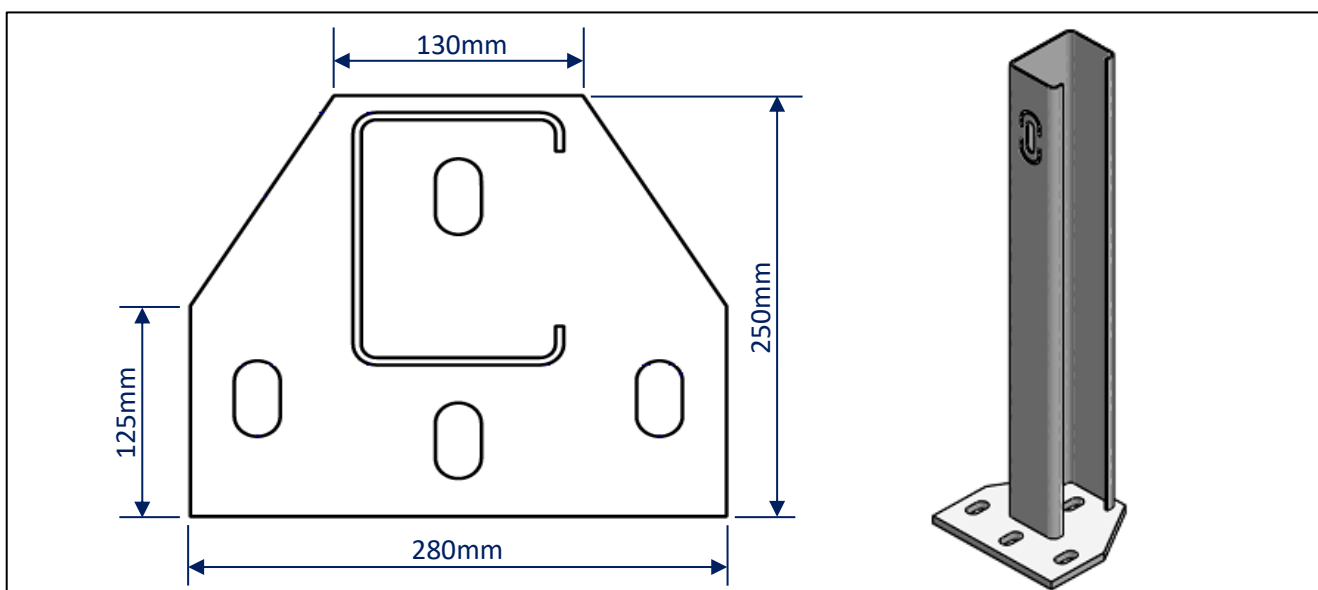

Figure 14: RamShield® Low Deflection Post on Baseplate

To further assist designers in circumstances when the post on baseplate will be secured to an existing footing or structure, Safe Direction has undertaken RamShield® Low Deflection post capacity analysis using LS-Dyna.

Analysis was undertaken using four (4) load conditions as shown in Figure 15 to identify the maximum loading condition.

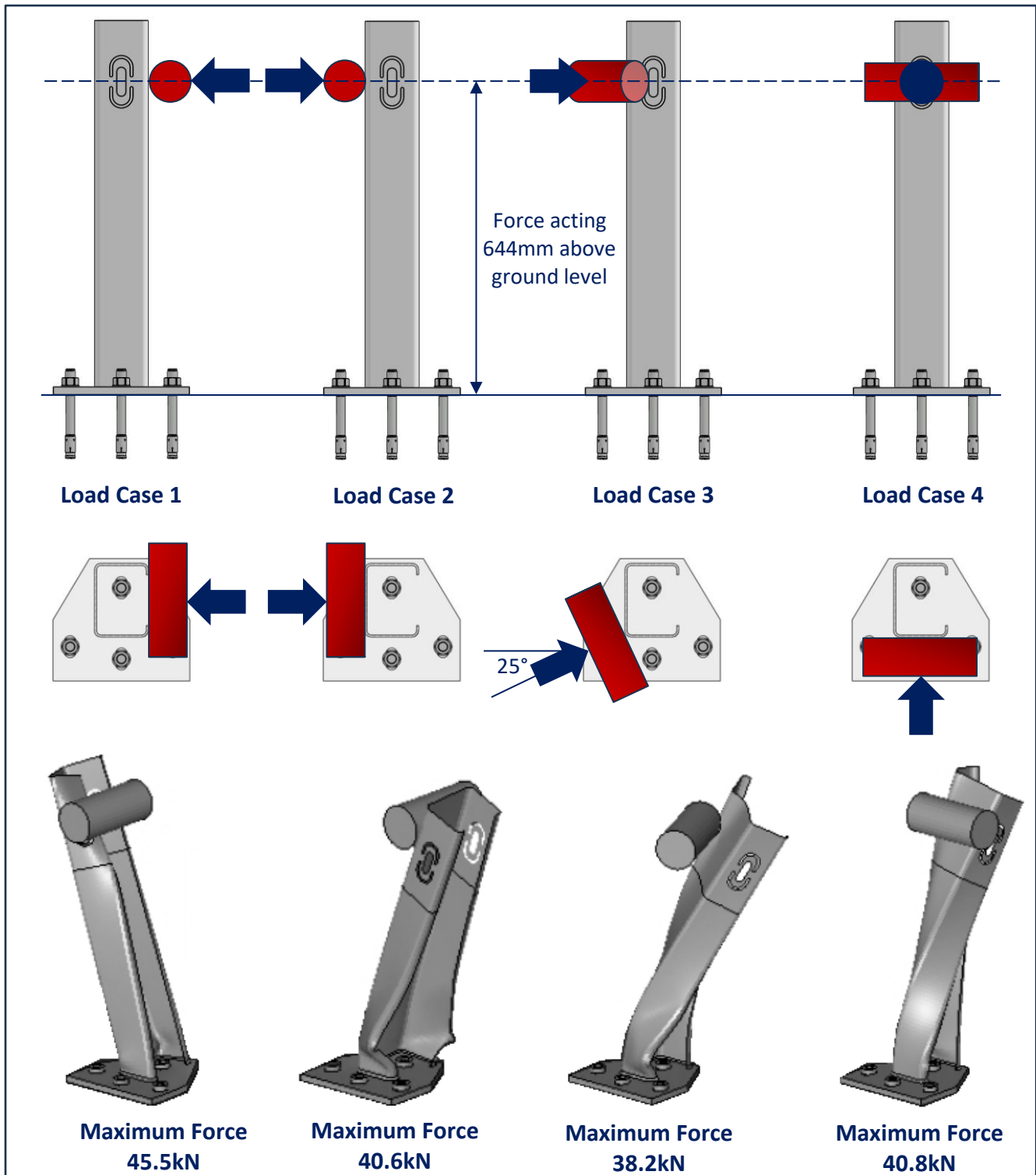

Figure 15: Load Capacity Analysis

6.19 Installation on Curves

W-beam guardrail barriers perform well on the outside of horizontal curves, even those of relatively small radius, as the concave shape (in plan view) supports the development of tension in the w-beam rail.

In the field, straight sections of w-beam can be used to form a horizontal radius of 45m or greater. When a radius of less than 45m is required, the w-beam rails are required to be factory curved. For ordering purposes, the orientation of curvature (i.e. concave or convex) and the radius is required by the manufacturer as shown in Figure 10.

There are no limitations regarding crest or sag vertical curves for the assembly of w-beam guardrail. Designers should refer to state road agency specifications for vertical alignment design guidelines. The minimum radius for crest vertical curvature is usually governed by sight distance requirements. Sag curves are generally designed as large as economically possible using the comfort criterion as a minimum.

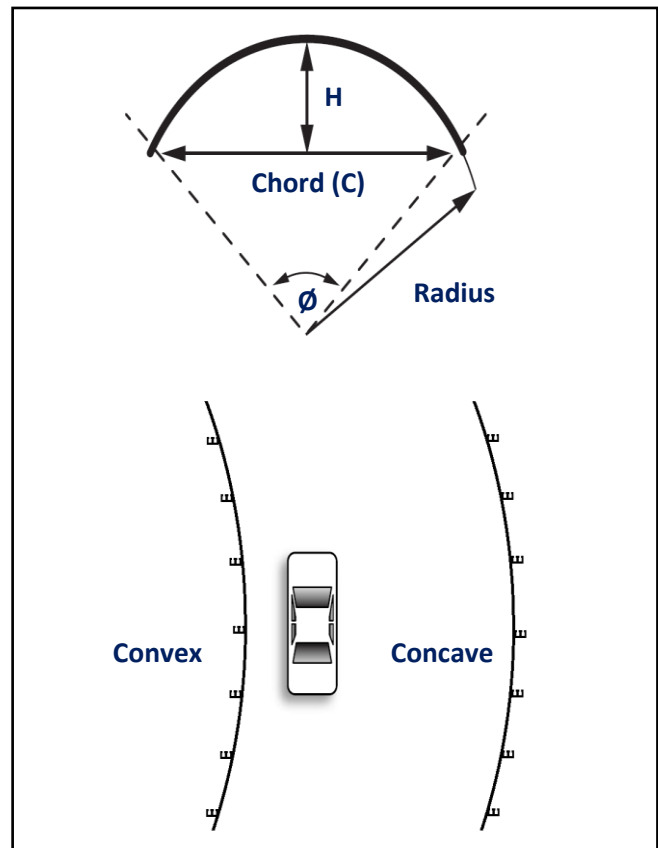

Figure 16: Horizontal Curving of W-Beam Guardrails





6.20 Design Life

The durability of the finished hot dip galvanized coating is a function of the environment to which the article is exposed. According to industry standards, hot-dip galvanized coatings can last up to 50 years in rural environments and up to 25 years in more corrosive environments, such as coastal regions. These estimates are based on average environmental conditions, and the actual lifespan of a galvanized coating will depend on the specific conditions it is exposed to.

Example: The RamShield® Low Deflection C-Post has a thickness of 4.3mm. Hot dip galvanising will provide a minimum average coating thickness of 70µm. When installed in a C3 environment, the coating will provide approximately 33 years until first maintenance.

Table 4: Coating Thicknesses as per AS/NZS 4680

Article Thickness (mm)	Average Coating Thickness (µm)	Average Coating Mass (g/m ²)
≤ 1.5	45	320
> 1.5 ≤ 3	55	390
> 3 ≤ 6	70	500
> 6	80	600

Table 5: Corrosivity Classifications as per AS 4312

Corrosivity Category	
CX	Severe surf shoreline
C5	Surf Seashore
C4	Calm Seashore
C3	Coastal
C2	Arid/Urban Inland
C1	Dry Indoors

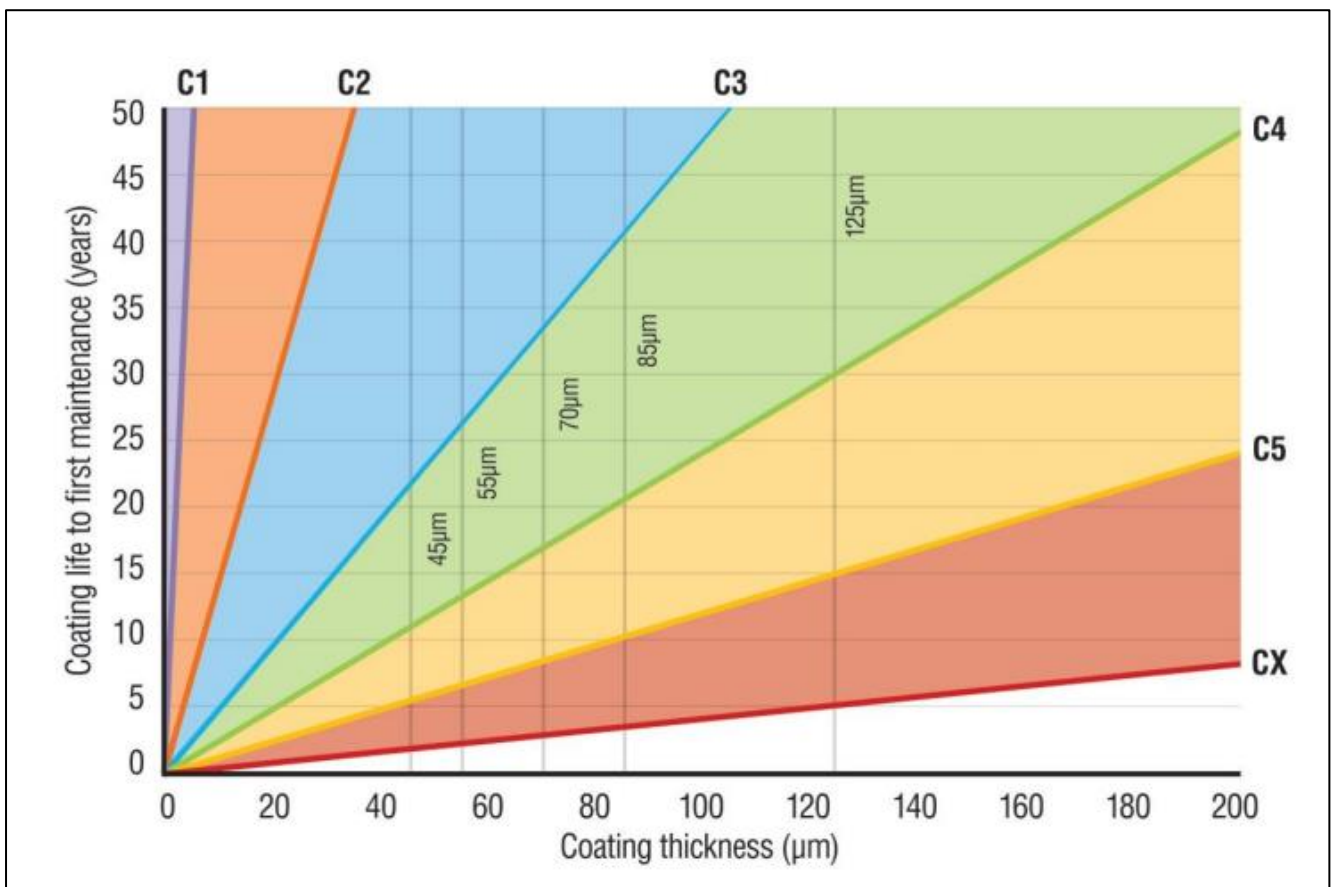
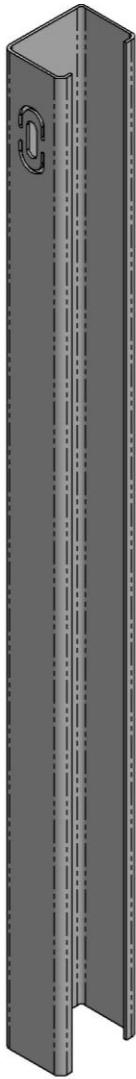

Figure 17: Calculated Corrosivity Rates for Hot Dip Galvanised Coatings from AS/NZS 2312.2



7.0 Component Identification (not to scale)



RamShield® C-Post
(for direct connection of w-beam)
21kg

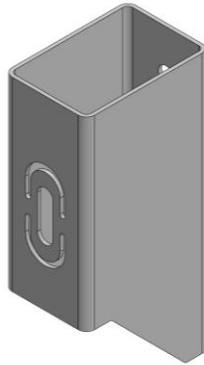

RamBloc®
5kg



RamShield® C-Post
(for use with RamBloc®)
21kg

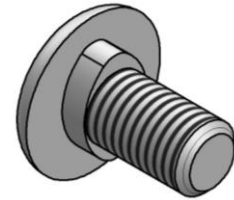

M16x32mm
Mushroom Head Bolt

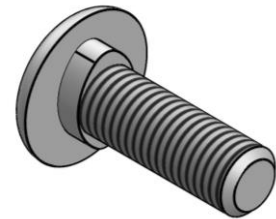

M16x50mm
Mushroom Head Bolt

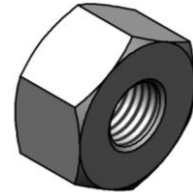

M16 Oversize Nut



M16 Standard Nut

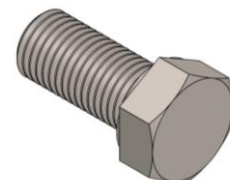

M16 x35mm
Hex. Head Bolt

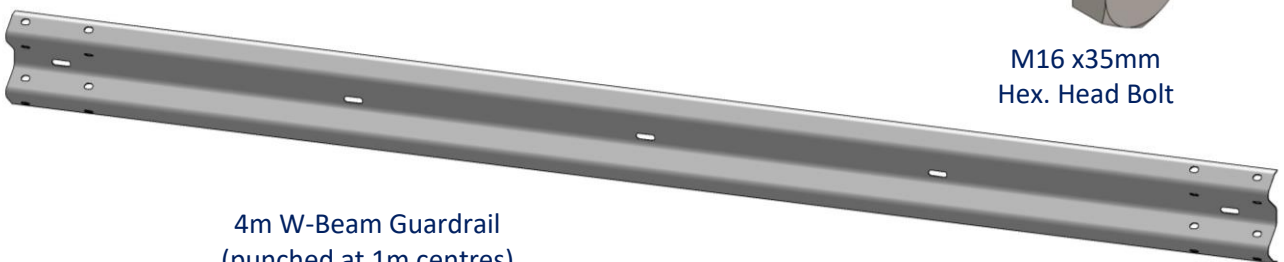

4m W-Beam Guardrail
(punched at 1m centres)
45kg



8.0 Tools Required

Tools required for the installation of RamShield® Low Deflection are the same as those used for the installation of public domain guardrail. This includes:

- Post driving equipment or auger.
- Battery drill driver with 32mm attachment.
- Hand socket with 24mm attachment.
- Metal snips.
- String line.
- Tape measure.
- Hammer.
- 12mm diameter pinch bar.
- Slings or chains.

8.1 Recommended PPE

It is recommended that the following personal protective equipment (PPE) be provided for the safe installation of RamShield® Low Deflection:

- Safety footwear.
- Gloves.
- Hearing protection.
- High visibility clothing.
- PPE as required for the use of post driving equipment or auger.

9.0 Site Establishment

9.1 Traffic Control

Prior to the commencement of any work, the site should be evaluated for risks to workers, pedestrians and other road users. The establishment of traffic control should provide safe travel for passing vehicles and/or pedestrians and appropriately protect workers near the roadside.

9.2 Underground Services

The installation of RamShield® Low Deflection requires the supporting C-posts to be embedded into the ground. Prior to the installation of posts an investigation for potential underground hazards is recommended.

9.3 Overhead Obstructions

The site should be evaluated for potential overhead obstructions that may present a risk during the installation process. These obstructions typically include power lines, signage or trees.

9.4 Unloading Exclusion Zone

Only appropriate load-rated slings or chains should be used for safe unloading. It is recommended that an exclusion zone be maintained around the unloading process. This provides distance between moving machinery and workers in the event that goods or the machinery move unexpectedly.

Unloading and the storing of the product on a level surface is recommended. Storing product adjacent to the installation area eliminates the requirement for workers to carry items over long distances.



10.0 Installation Sequence

The major steps in the installation of RamShield® Low Deflection are as follows:

- Set-out.
- Installing the approach terminal.
- Installing the RamShield® Low Deflection C-posts.
- Installing the RamBlocs® (optional)
- Attachment of the w-beam guardrail.
- Installing the departure terminal or transition to rigid barrier.
- Attachment of delineation (if required).

11.0 Set-Out

It is recommended that a string line be used to establish the alignment of the post locations. When establishing the post locations, take care to note the following:

- The rail splice locations of RamShield® Low Deflection are mid-span between C-posts.
- RamShield® Low Deflection may be installed with or without RamBlocs®.
- The standard post spacing of RamShield® Low deflection is 2.0m.
- The 2.0m post spacing of RamShield® Low Deflection may differ from the post spacing of the end terminals or transitions.
- The system width of RamShield® Low Deflection may differ from the system width of the end terminals and transitions.
- The RamShield® Low Deflection C-posts are not to be installed within the terminal or transition region.





12.0 Post Installation

Potential Hazards: Use of post driving equipment or auger, contact with underground hazards, excessive noise, hand injury from pinch points and injury from movements and posture.

Recommended Control Measures: Observe the safe work instructions as per machinery requirements, ensure the area has been inspected for underground hazards, wear appropriate hearing protection, wear gloves and observe correct techniques when lifting (bend at the knees).

The C-posts may be installed by:

- Driving with an appropriate driving head to the required depth, approximately 890mm, or
- Auguring a minimum 200mm diameter hole approximately 890mm deep, placing the post in the hole and backfilling. The backfill material is to be placed in 150mm lifts and compacted with tamping equipment.

Once installed, the top of the C-post should measure 770mm above ground level.

13.0 Attaching RamBlocs®

Potential Hazards: Hand injury from pinch points and injury from movements and posture.

Recommended Control Measures: Wear gloves and observe correct posture.

The use of RamBlocs® is optional and considers whether an offset between the face of the rail and the alignment of the posts is desirable.

The steel RamBloc® is manufactured from 150x150mm SHS. Each RamBloc® is secured to the C-post with two (2) M16x35mm hex head bolts and standard nuts. The standard nut is tightened using a hand socket and 24mm attachment.

14.0 Attaching the W-Beam Rails

Potential Hazards: Injury from movements and posture, hand injury from pinch points, strain to wrists from tightening bolts and excessive noise from use of impact driver.

Recommended Control Measures: Observe correct techniques when lifting rails (bend at the knees), wear gloves, use a pinch bar to align holes, use an impact drill to tighten bolts and wear appropriate hearing protection.

W-beam guardrails manufactured by Safe Direction are punched at 1m centres providing compatibility for all RamShield® variants.

The rails should be positioned ensuring the rail splice is located mid-span between C-posts.

The rails are secured to the C-posts (or optional RamBlocs®) using a M16 x 50mm mushroom head bolt and oversize nut. The oversize nut is tightened using a hand socket and 32mm attachment.

The guardrail lap is orientated so that the leading edge of the splice is shielded from the nearside approaching traffic. Rails are spliced together mid-span between C-posts using eight (8) standard M16 x 32mm mushroom head bolts and oversize nuts. The oversize nuts are tightened using a battery drill driver and 32mm attachment.

The use of a pinch bar will assist in aligning the splice holes as the bolts are inserted. The use of a driving pin to elongate the splice holes is NOT permitted.

There is no torque requirement for the tightening of the post bolts or splice bolts. They should be tightened to a snug position.

Once secured to the C-posts, the finishing height of the guardrail will be approximately 30mm above the top of the C-posts (or optional RamBlocs®).

Note: A M16 x 32mm mushroom head bolt may be used as an alternative to secure the rails to the posts (or optional RamBlocs®).



15.0 Recommended Tolerances

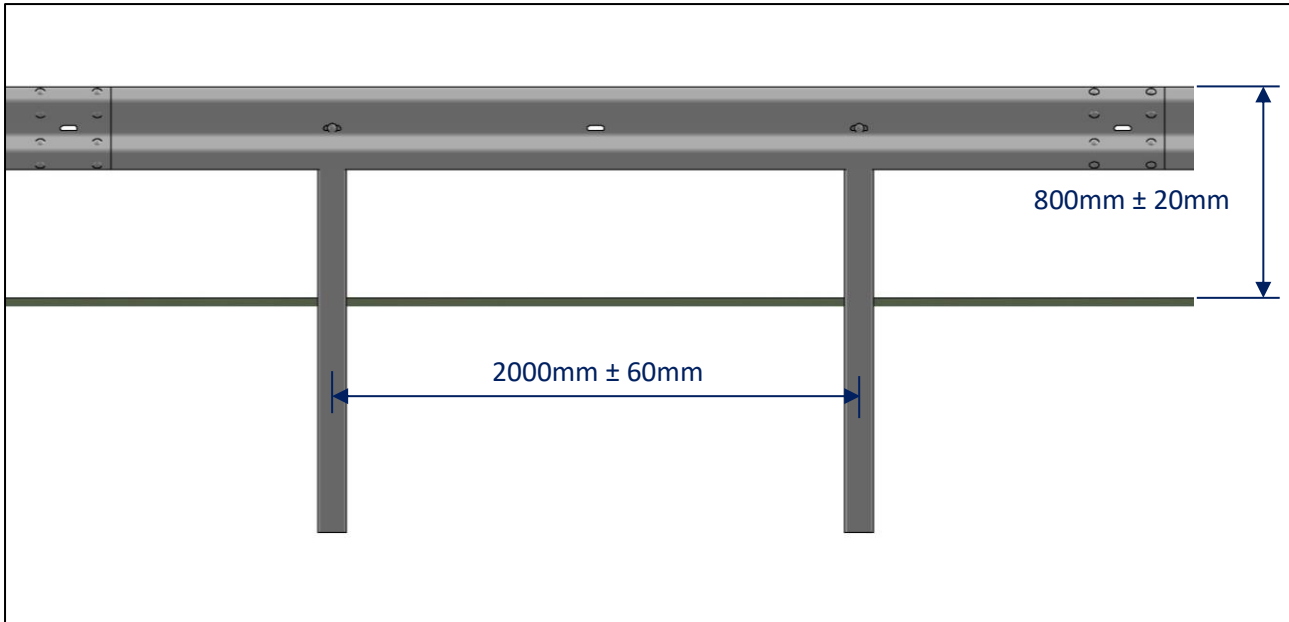

Figure 18: Recommended Installation Tolerances.





RamShield® LD Inspection Form

Inspection Date	
Client	
Project Reference	
Name of Inspector	
Company	

<input type="checkbox"/> Yes <input type="checkbox"/> No	The system is suitably anchored with approved state road agency end terminals.
<input type="checkbox"/> Yes <input type="checkbox"/> No	The C-posts are spaced at maximum 2.0m centres.
<input type="checkbox"/> Yes <input type="checkbox"/> No	The height measured to the top of the C-posts (or optional RamBlocs®) is approximately 770mm.
<input type="checkbox"/> Yes <input type="checkbox"/> No	If RamBlocs® are installed, they are secured to each post with two (2) M16 x 35mm hexagonal head bolts & standard nuts.
<input type="checkbox"/> Yes <input type="checkbox"/> No	The C-posts are correctly orientated with the release tab on the traffic side.
<input type="checkbox"/> Yes <input type="checkbox"/> No	The height measured to the top of the w-beam rails is 800mm ± 20mm.
<input type="checkbox"/> Yes <input type="checkbox"/> No	The rail is secured to each C-post (or optional RamBloc®) with a M16 x 50mm (or 32mm) mushroom head bolt & oversize nut.
<input type="checkbox"/> Yes <input type="checkbox"/> No	The rails are spliced mid-span between C-posts with eight (8) M16 x 32mm mushroom head bolt & oversized nuts.
<input type="checkbox"/> Yes <input type="checkbox"/> No	The rail lap is orientated so that the leading edge of the splice is shielded from approaching traffic.
<input type="checkbox"/> Yes <input type="checkbox"/> No	All bolts are tightened.
<input type="checkbox"/> Yes <input type="checkbox"/> No	The fill material around the posts is suitably compacted.
<input type="checkbox"/> Yes <input type="checkbox"/> No	Any minor damage to the galvanised finish is repaired using two coats of an organic zinc rich paint.
<input type="checkbox"/> Yes <input type="checkbox"/> No	The barrier is appropriately delineated (if required).
<input type="checkbox"/> Yes <input type="checkbox"/> No	The area around the barrier is free of debris.

Comments/Notes



16.0 Maintenance

RamShield® Low Deflection is a low maintenance barrier. Except for repairs due to impacts, it is recommended that an annual inspection be undertaken to assess the following:

- The barrier is appropriately delineated (if required).
- Debris has not accumulated around the barrier which may impede the function of the barrier.
- Vegetation around the barrier is appropriately maintained.
- Nuisance impacts have not gone undetected.
- The anchor assembly at the end terminals is taut and the bearing plate is correctly aligned.

17.0 Dismantling

Should RamShield® Low Deflection require dismantling, it is recommended that the guidelines contained in Section 9.0 be observed in the establishment of traffic control in addition to an investigation for underground services and overhead obstructions.

17.1 Removing the W-Beam Rails

Potential Hazards: Injury from movements and posture, hand injury from pinch points, strain to wrists from loosening bolts and excessive noise from use of impact driver.

Recommended Control Measures: Observe correct techniques when lifting rails (bend at the knees), wear gloves, use an impact drill to loosen bolts and wear appropriate hearing protection.

Using a battery drill driver and 32mm attachment, loosen the eight (8) M16 oversize nuts and remove the M16 x 32mm mushroom head splice bolts.

Remove the M16 x 50mm mushroom head bolt and oversize nut securing the w-beam rail to the C-posts (or optional RamBlocs®).

17.2 Removing the RamBlocs®

Potential Hazards: Hand injury from pinch points and injury from movements and posture.

Recommended Control Measures: Wear gloves and observe correct posture.

The use of RamBlocs® is optional and considers whether an offset between the face of the rail and the alignment of the posts is desirable.

The RamBlocs are removed by loosening the two (2) M16x35mm hex head bolts and standard nuts.

17.3 Removing the C-Posts

Potential Hazards: Use of post extracting equipment or auger, contact with underground hazards, excessive noise, hand injury from pinch points and injury from movements and posture.

Recommended Control Measures: Observe the safe work instructions as per machinery requirements, ensure the area has been inspected for underground hazards, wear appropriate hearing protection, wear gloves and observe correct techniques when lifting (bend at the knees).

Posts should be removed using an appropriate post extractor. Once the post is removed, the ground material should be suitably compacted.



18.0 Repair

In the event of a vehicle impact, damage to the barrier is to be assessed in accordance with Table 7. Typically, impacts with RamShield® Low Deflection will require replacement of damaged sections of rails, C-posts and RamBlocs® (if fitted). It is also recommended that new bolts be used where rails, C-posts and RamBlocs® (if fitted) have been replaced.

RamShield® Low Deflection components are all-steel and may be recycled when replaced.

Additional tools required for repair include:

- Acetylene torch to cut away damaged rail.
- Heavy duty chain to remove damaged posts.
- Sledge hammer.
- Post extractor.

Similar to the installation sequence, it is recommended that the guidelines contained in Section 9.0 be observed in the establishment of traffic control and an unloading exclusion zone in addition to an investigation for underground services and overhead obstructions.

18.1 Removal of Damaged Posts

Potential Hazards: Hand injury from pinch points, hand injury from damaged edges and injury from sudden movement as the posts are released.

Recommended Control Measures: Wear gloves and maintain an appropriate exclusion zone around the post until removed.

Damaged posts should be removed using an appropriate post extractor. Once the damaged post is removed, the ground material should be suitably compacted before a replacement post is installed.

Upstream and downstream posts outside of the impact area should also be inspected for movement and the surrounding ground material recompact if required.

18.2 Removal of Damaged Rails

Potential Hazards: hand injury from pinch points, hand injury from damaged edges, injury from sudden movement as rails are released and excessive noise from use of impact drill.

Recommended Control Measures: Wear gloves and wear appropriate hearing protection.

Using an impact drill, remove the splice bolts at the rail connection. Rails that have twisted or bent during impact may need to be cut into manageable sections using an acetylene torch.

Upstream and downstream rails outside of the impact area should also be inspected for any minor knicks or elongation of the post slots.



Re-compact ground material after removal of damaged post(s).



Table 7: Damage Assessment Guidelines

Type of Damage	Description of the Damage	Remedial Action
Damage to the galvanised coating on the C-posts.	The sum total of the damaged area does not exceed 60cm ² (0.5% of the total surface area).	An organic zinc rich paint is to be applied to the repair area in two coats.
	The sum total of the damaged area exceeds 60cm ² (0.5% of the total surface area).	The post is to be replaced.
Damage to the galvanised coating on the rails.	The sum total of the damaged area does not exceed 200cm ² (0.5% of the total surface area) and no individual damaged area exceeds 40cm ² .	An organic zinc rich paint is to be applied to the repair area in two coats.
	The sum total of the damaged area exceeds 200cm ² (0.5% of the total surface area) or an individual damaged area exceeds 40cm ² .	The rail is to be replaced.
Damage to the C-posts.	The C-post is bent.	The C-post is to be replaced.
Damage to the RamBlocs [®] (if fitted).	The shape of the RamBloc [®] is distorted.	The RamBloc [®] is to be replaced.
Damage to the release tab.	The tab has distorted and released the post bolt.	The C-post or RamBloc [®] (if fitted) is to be replaced.
Damage to the rails.	The rail is dented, twisted or flattened.	The rail is to be replaced.
	There are nicks in any part of the rail.	
	The slots in the rail are distorted.	
Damage to bolts.	The body of the bolt is distorted.	The bolt is to be replaced.
	The thread of the bolt is damaged.	
Disturbance of material around the posts.	The material around a post is loose.	The material is to be suitably compacted.



SafeDirection

CRASH BARRIER SOLUTIONS



 1300 063 220

sales@safedirection.com.au

ABN 53 156 459 684

safedirection.com.au