

CrocGuard®

Up to 16m Free Span Barrier

Compliant to MASH



SafeDirection
CRASH BARRIER SOLUTIONS

safedirection.com.au



Table of Contents

1.0	Introduction	5
2.0	Specifications	5
3.0	Crash Test Performance.....	6
4.0	Design Considerations	8
4.1	Alignment with Edge of Bridge or Culvert.....	8
4.2	Hydraulic Load	8
4.3	Advance Grading.....	8
4.4	Clearance to Hazards	8
4.5	System Installed Height.....	9
4.6	CrocGuard® Length Selection	9
4.7	The RamShield® Transition.....	9
4.8	Connecting to RamShield® W-Beam.....	10
4.9	Connecting to RamShield® HC.....	11
4.10	End Terminals	12
4.11	Minimum Installation Length	13
4.12	Point of Redirection.....	13
5.0	CrocGuard® Component Identification.....	14
6.0	Tools Required	15
6.1	Recommended PPE.....	15
7.0	Site Establishment.....	15
7.1	Traffic Control	15
7.2	Underground Services.....	15
7.3	Overhead Obstructions	15
7.4	Unloading Exclusion Zone & Storage	15
7.5	Site Preparation.....	17
8.0	CrocGuard® Installation.....	17
8.1	Set-out.....	17
8.2	Auguring the Abutment Post Holes.....	17
8.3	Lifting the CrocGuard® Beams.....	17
8.4	Attaching the Abutment Post.....	19
8.5	Concreting the Abutment Post	19
8.6	Installing the RamShield® Transition.....	19
	CrocGuard® Inspection Form.....	25
9.0	Maintenance	26
10.0	Repair.....	26





Leading Safety

Spanning up to 16m without posts

Crash tested to Regular Performance Level as defined in AS 5100:2017 Bridge Design

Compliance to MASH TL3 & TL4

Evaluated for connection to the MASH TL3 RamShield® Transition

Simplified Installation

Available in modular lengths of 8m, 10m, 12m, 14m or 16m

Supplied as a preassembled beam

Connects directly to the RamShield® Transition

Rapid installation minimises road closure duration

Design Benefits

No attachment to the bridge or culvert structure

No additional hydraulic load on bridges from overtopping floodwater

Minimises potential for debris entrapment during overtopping floodwater

Maximises usable bridge & culvert width reducing centre line crowding

Eliminates the requirement for ground beam when spanning underground services

Robust and highly resilient to nuisance impacts

Minimal maintenance



1.0 Introduction

Developed by Safe Direction, CrocGuard® is a revolutionary barrier system spanning up to 16m between abutment posts.

Featuring a unique composite design comprising external thrie-beam rails that encases a concrete core, the system transfers impact loads to the posts at each abutment.

The stiffness of CrocGuard® limits dynamic deflection and minimises damage to the barrier following nuisance impacts.

CrocGuard® is available in modular lengths of 8m, 10m, 12m, 14m and 16m providing a tailored solution for various applications including:

- Weak bridge decks such as timber deck bridges that have insufficient structural capacity to withstand vehicle impact loads from a conventional post and rail barrier;
- Culvert applications where there is insufficient fill height to support posts or a strip footing for conventional post and rail barrier
- Concern for horizontal hydraulic loads experienced by the bridge or culvert during flood events;
- Narrow bridges or culverts in need of maximising lane widths; and
- Areas where underground services or obstructions prevent the installation of a strip footing for a conventional post and rail barrier

CrocGuard® is compatible with the MASH TL3 RamShield® Transition which can connect directly to RamShield® High Containment, RamShield® W-Beam or the MSKT Terminal providing a fully MASH compliant barrier system.

CrocGuard® is a patented system designed, crash test validated, manufactured and supplied by Safe Direction, a proud Australian owned manufacturing company.

2.0 Specifications

Crash Test Compliance:

- Regular Performance Level as per AS 5100
- MASH TL4 and TL3 as per AS/NZS 3845.1

Maximum Span:

- 16m between abutment posts

System Width:

- 280mm measured between faces of Thriebeam rail

Deflection:

- MASH TL4 deflection 16m beam: 0.90m
- MASH TL3 deflections as per Table 1

Table 1: MASH TL3 Deflections

Beam Length	Deflection
16m	0.82m
14m	0.66m
12m	0.50m
10m	0.42m
8m	0.33m

Note:

- 16m deflection based on crash testing
- 12m and 8m deflection based on validated simulation model
- 14m and 10m deflections interpolated

Thriebeam Finish:

- Hot dip galvanised to AS/NZS 4680





3.0 Crash Test Performance

CrocGuard® has been fully crash tested and evaluated according to the AASHTO Manual for Assessing Safety Hardware (MASH). The MASH specification is an update to and supersedes NCHRP Report 350 for the purposes of evaluating new safety hardware devices.

MASH is also the basis of testing procedures for road safety systems as stated in *AS/NZS 3845.1: 2015 Road Safety Barrier System and Devices* and bridge barriers as stated in *AS 5100:2017 Bridge Design*.

The introduction of MASH follows changes to the vehicle fleet, researching of real-life impact conditions and updated criteria for evaluating barrier performance.



CrocGuard® has been crash tested as detailed in Table 2.

Table 2: CrocGuard® Crash Test Compliance

Australian Standard	Reference	Required Impacts
AS/NZS 3845.1 2015 Road Safety Barrier System and Devices	MASH TL3	1100kg passenger car travelling at 100km/h and 25° 2270kg pick-up truck travelling at 100km/h and 25°
AS 5100:2017 Bridge Design Series	Regular Barrier Performance Level MASH TL4	1100kg passenger car travelling at 100km/h and 25° 2270kg pick-up truck travelling at 100km/h and 25° 10,000kg rigid truck travelling at 90km/h and 15°





Figure 1: Crash Test Impact: 1100kg Passenger Car, 100km/h and 25 degrees



Figure 2: Crash Test Impact: 2270kg Pick-up Truck, 100km/h and 25 degrees



Figure 3: Crash Test Impact: 10,000kg Rigid Truck, 90km/h and 15 degrees



4.0 Design Considerations

4.1 Alignment with Edge of Bridge or Culvert

CrocGuard® beams up to and including 14m (between abutment posts) may be installed with the traffic face of the beam aligned with the edge of the bridge or culvert deck.

Beams longer than 14m (between abutment posts) must have a minimum 100mm encroachment, measured from the edge of the deck to the traffic face of the beam. Refer to Figure 1.

4.2 Hydraulic Load

CrocGuard® effectively eliminates the often-destructive hydraulic load applied to bridges and culverts from conventional post and rail barriers during overtopping from flood waters.

The clear space beneath the CrocGuard® barrier facilitates overflows, reducing maintenance costs and providing greater surety to the life expectancy of bridges and culverts.

4.3 Advance Grading

It is recommended that the area in advance of the CrocGuard® be limited to a grading of 10H:1V to ensure that the vehicle's suspension is neither extended nor compressed at the moment of impact with the barrier.

4.4 Clearance to Hazards

For non-bridge & culvert applications, the CrocGuard® barrier should be installed with sufficient clearance behind the barrier to allow for the expected deflection of the system. Reference Table 1.

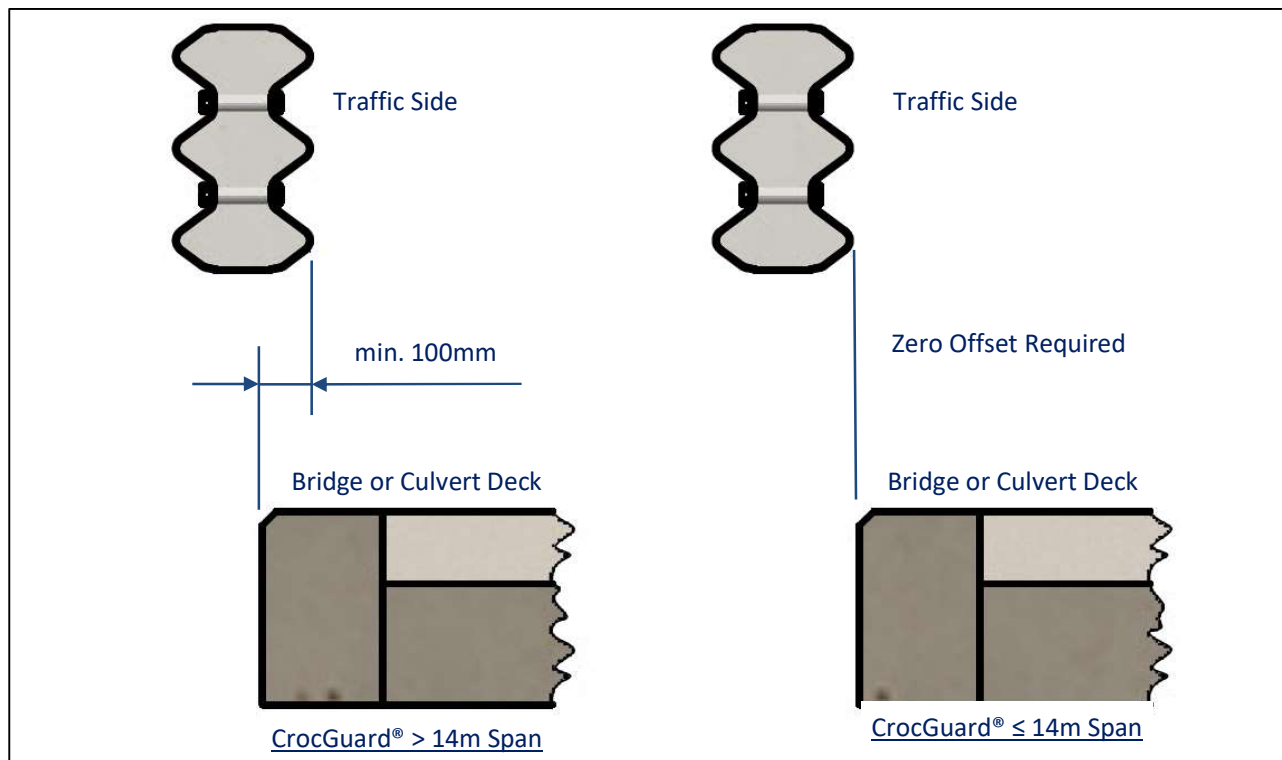

Figure 4: CrocGuard® Alignment with Edge of Bridge or Culvert Deck



4.5 System Installed Height

The installed height of CrocGuard® is 980 ± 40mm above ground or deck level. This installation height is compatible with the RamShield® Transition.

4.6 CrocGuard® Length Selection

Care is required to nominate an appropriate length of CrocGuard® barrier. Typically, the length of the CrocGuard® barrier is 2m longer than the actual length of bridge or culvert.

The additional length of barrier is required to ensure that the abutment posts that support CrocGuard® are appropriately located in sound foundation material and formation geometry.

4.7 The RamShield® Transition

The RamShield® Transition provides a smooth, snag-free connection between CrocGuard® and steel guardrail barriers. The RamShield® Transition gradually increases stiffness of the guardrail system reducing the potential for vehicle pocketing at the CrocGuard® abutment post.

The RamShield® Transition has been full-scale crash tested in accordance with MASH TL3 when connected to CrocGuard®.

The RamShield® Transition achieves a controlled redirection of errant vehicles by releasing the three-beam guardrail from the post at an optimal load to retain rail height, limit dynamic deflection and to allow the post to collapse without tripping the vehicle.

The separation of the rail from the post is achieved by a release tab incorporated into the C-post. The tab controls the release of the rail within the impact zone providing stable vehicle containment and redirection with minimal vehicle roll.

The C-posts collapse upon impact yielding proximate to the ground surface. The sectional strength of the C-post limits barrier deflection, an important design consideration when reducing the potential for vehicle pocketing.





4.8 Connecting to RamShield® W-Beam

The RamShield® Transition features an asymmetric transition when connecting to RamShield® W-Beam.

The asymmetric transition lowers the height to top of the thrie-beam rail by 200mm, making it compatible for use with RamShield® W-Beam guardrail and MSKT terminals, which are installed with a rail height of 800mm above ground level.

Typically, RamShield® W-Beam is installed with posts at 2m centres, however when connecting to the RamShield® Transition, the 4m prior to the asymmetric transition is installed with posts at 1m centres. This arrangement gradually stiffens the RamShield® W-Beam barrier as it transitions to thrie-beam.

Safe Direction w-beam guardrails are pre-punched at 1m centres to facilitate the reduced post spacing.

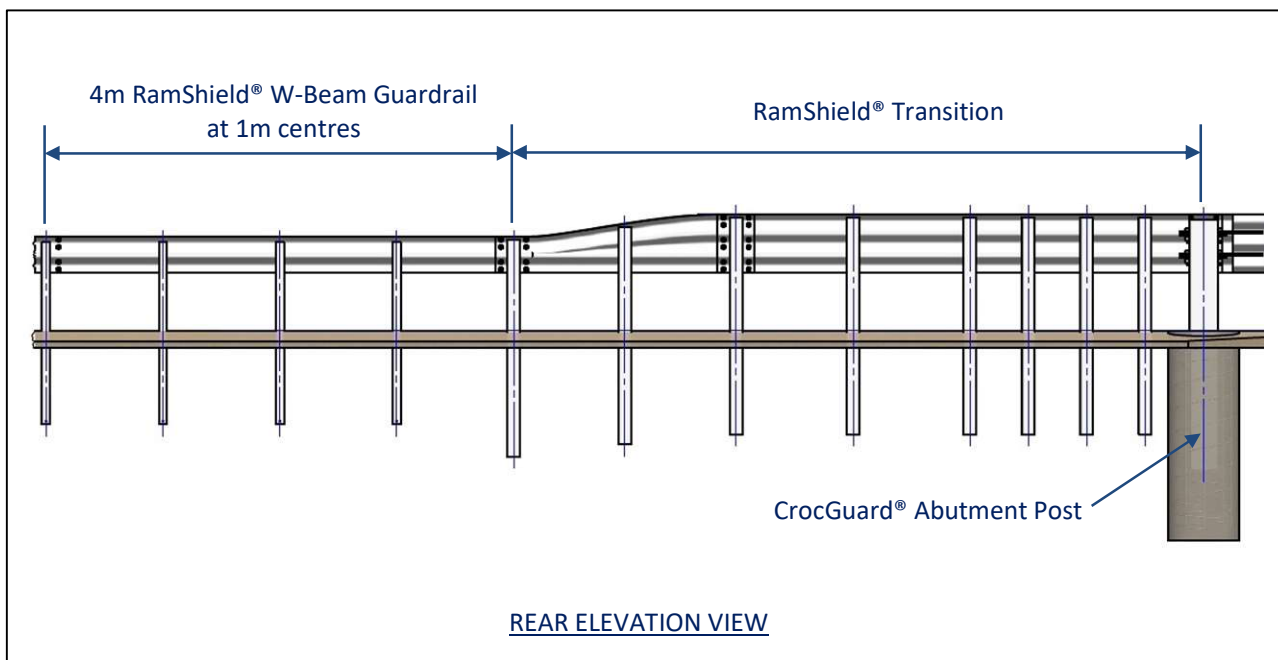

Figure 5: CrocGuard® Connection to RamShield® W-Beam





4.9 Connecting to RamShield® HC

The RamShield® Transition can be connected directly to RamShield® High Containment (HC) without an asymmetric transition piece.

The RamShield® Transition uses the same post as RamShield® HC and adopts the same system height, simplifying connection between the two systems.

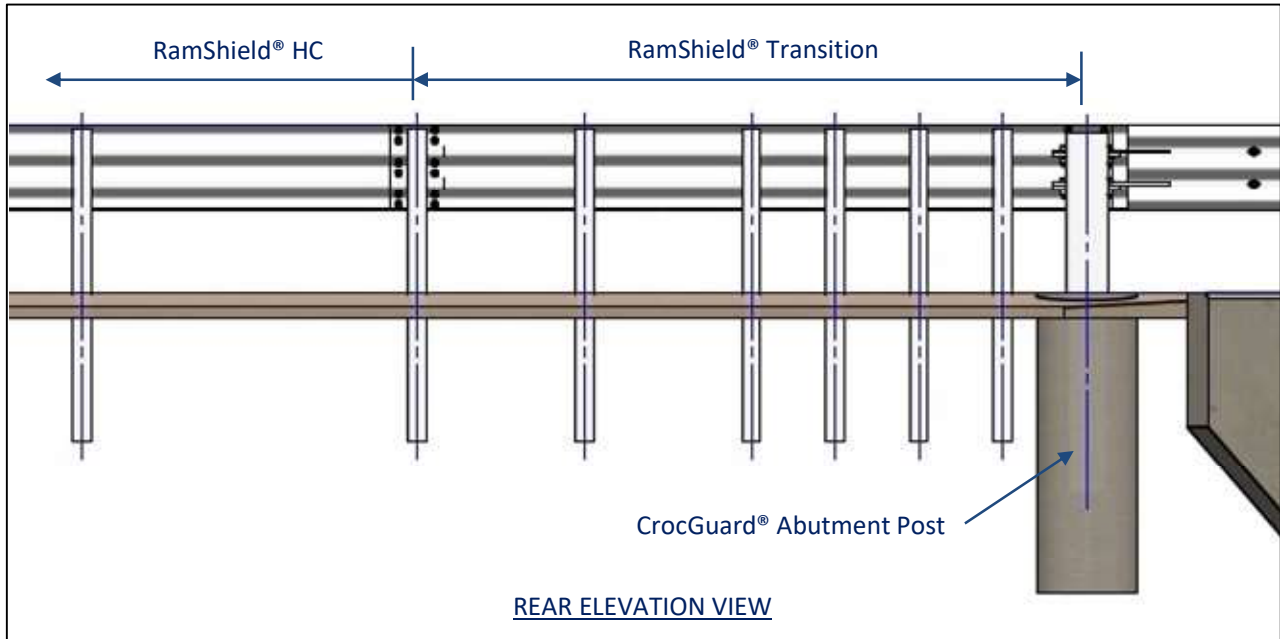

Figure 6: CrocGuard® Connection to RamShield® HC





4.10 End Terminals

End terminals are designed to anchor the safety barrier system and introduce the necessary tensile and flexural strength required for safe vehicle containment and re-direction throughout the length-of-need section. They also provide the additional feature of reducing the severity of an impact near or at the end of the system.

Guardrail end terminals are installed using w-beam guardrail, therefore it is necessary to transition from thrie-beam using an asymmetric transition before commencing installation of an end terminal. Thrie-beam cannot be used within the guardrail terminal section.

The MASH compliant SKT (MSKT) is an energy-absorbing tangential end terminal, designed to minimise the severity of impacts occurring at the end of the safety barrier system.

It is required that all CrocGuard® installations be anchored with suitable guardrail end terminal.

The MSKT Terminal can connect directly to the w-beam end of the asymmetric transition installed as part of the RamShield® Transition.

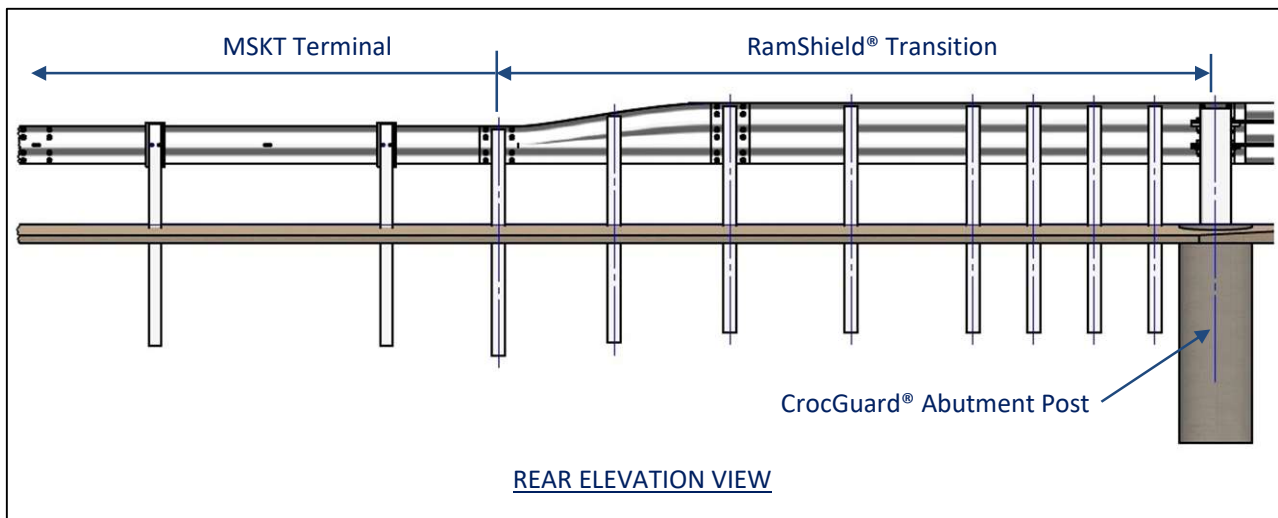

Figure 7: CrocGuard® Connection to MSKT Terminal





4.11 Minimum Installation Length

It is recommended, where space permits, to install continuous safety barrier rather than designing a barrier to shield a specific hazard(s). A continuous safety barrier aims to protect the entire roadside and prevent vehicle rolling, impacts with hazards or head-on collisions.

When space is limited the minimum installation length of a CrocGuard® system may comprise a RamShield® Transition connecting to a MSKT Terminal.

The minimum installation lengths, measured from the leading end terminal to the departure end terminal are detailed in Tables 3 and 4 for speed zones greater than 70km/h and less than equal to 70km/h respectively.

Table 3: Minimum Installation Lengths, Post Speed > 70km/h

CrocGuard® Span Length	MASH TL3 Terminal (req. both ends of the system)	RamShield® Transition Length	Minimum Installation Length
8m	14.3m TL3 MSKT	5.9m	48.4m
10m	14.3m TL3 MSKT	5.9m	50.4m
12m	14.3m TL3 MSKT	5.9m	52.4m
14m	14.3m TL3 MSKT	5.9m	54.4m
16m	14.3m TL3 MSKT	5.9m	56.4m

Table 4: Minimum Installation Lengths, Post Speed ≤ 70km/h

CrocGuard® Span Length	MASH TL2 Terminal (req. both ends of the system)	RamShield® Transition Length	Minimum Installation Length
8m	9.5m TL2 MSKT	5.9m	38.8m
10m	9.5m TL2 MSKT	5.9m	40.8m
12m	9.5m TL2 MSKT	5.9m	42.8m
14m	9.5m TL2 MSKT	5.9m	44.8m
16m	9.5m TL2 MSKT	5.9m	46.8m

4.12 Point of Redirection

AS/NZS 3845.1: 2015 Road Safety Barrier System and Devices defines the point of redirection as the location along the length of a longitudinal road safety barrier where the impacting vehicle interaction changes from gating to redirection.

When specified as a MASH TL3 longitudinal safety barrier system, the entire length of CrocGuard®, the RamShield® Transition and any additional upstream or downstream RamShield® barrier provides containment of a 2270kg pick-up truck travelling at 100km/h and 25 degrees.

When anchored with a MSKT Terminal, the point of redirection commences at the 3rd post of the MSKT.



5.0 CrocGuard® Component Identification

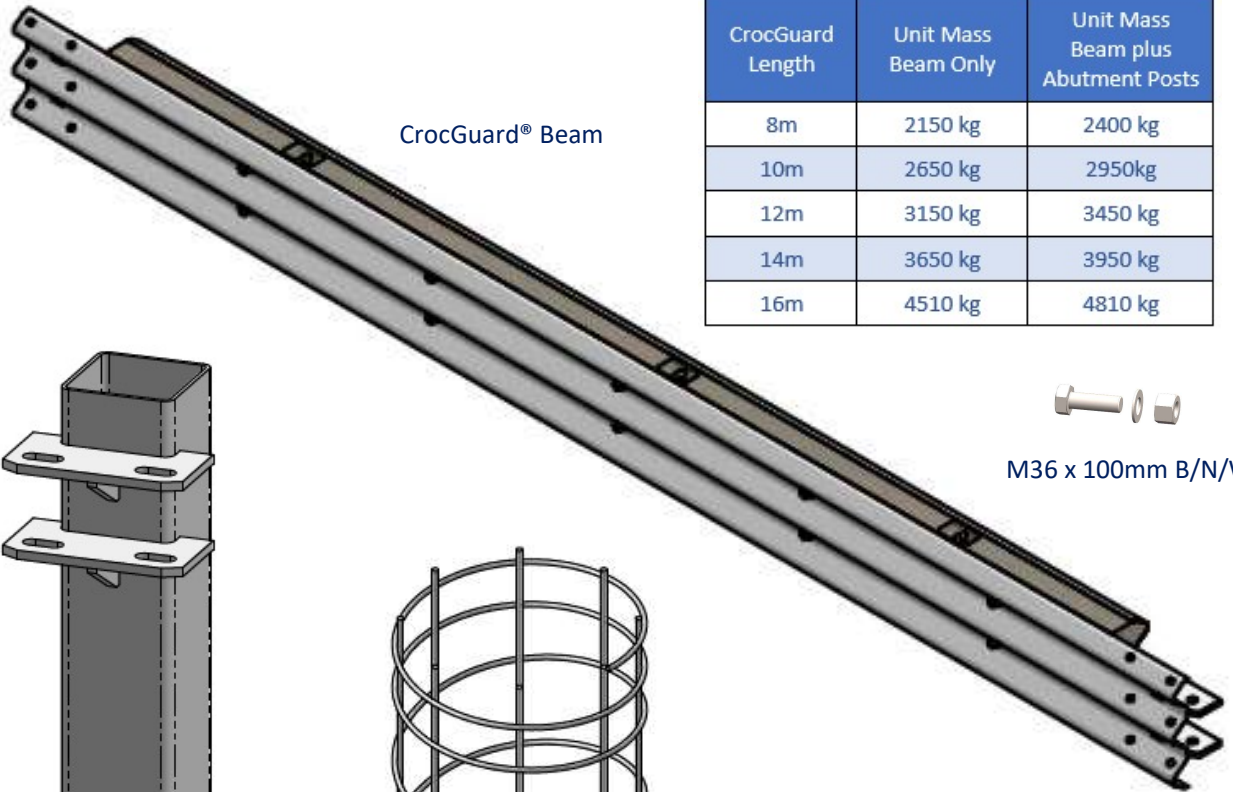

CrocGuard Length	Unit Mass Beam Only	Unit Mass Beam plus Abutment Posts
8m	2150 kg	2400 kg
10m	2650 kg	2950kg
12m	3150 kg	3450 kg
14m	3650 kg	3950 kg
16m	4510 kg	4810 kg



M36 x 100mm B/N/W

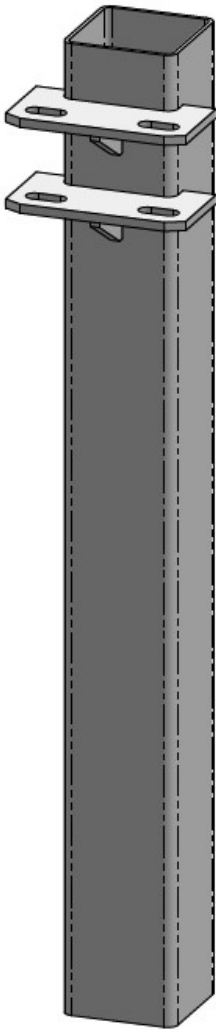

2150mm Abutment Post
250x250x9 SHS
150 kg each

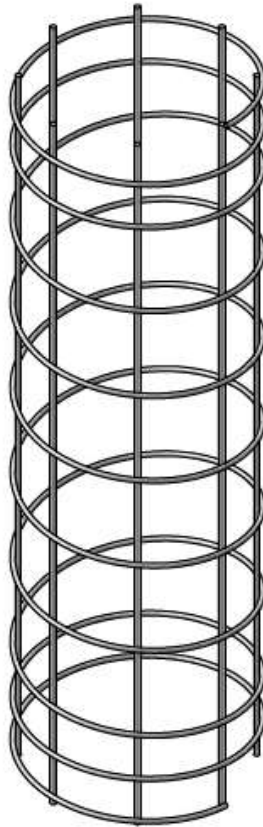

1600mm Abutment Post
Reinforcing Cage
11 kg each

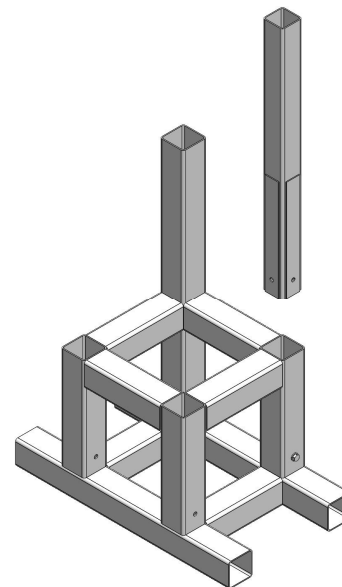

Installation Support Frame
16 kg each (SWL 5 tonnes)



6.0 Tools Required

Tools required for the installation of CrocGuard® include:

- Crane to suit CrocGuard® beam mass;
- 600mm diameter auger;
- Combination spanner to suit M36 bolts (2 off);
- Pneumatic drill driver with 32mm attachment;
- String line;
- Tape measure;
- Plate clamp;
- Metal snips;
- Concrete trowel;
- Sledge hammer;
- Shovel;
- 12mm diameter pinch bar; and
- Slings or chains.

6.1 Recommended PPE

It is recommended that the following personal protective equipment (PPE) be provided for the safe installation of the CrocGuard®:

- Safety footwear;
- Hard hat;
- Gloves;
- Hearing protection;
- High visibility clothing; and
- PPE as required for the use of an auger.

7.0 Site Establishment

7.1 Traffic Control

Prior to the commencement of any work, the site should be evaluated for risks to workers, pedestrians and other road users. The establishment of traffic control should provide safe travel for passing vehicles and/or pedestrians and appropriately protect workers near the roadside.

Installation of CrocGuard® will require a minimum single lane closure for installation. Depending on the lifting crane/apparatus deployed a two-lane bridge can be kept open during installation as a traffic-controlled single lane operation.

7.2 Underground Services

The installation of the CrocGuard® abutment posts and adjoining RamShield® Transitions requires the supporting posts to be embedded into the ground. Prior to the installation of posts an investigation for potential underground hazards is recommended.

7.3 Overhead Obstructions

The site should be evaluated for potential overhead obstructions that may present a risk during the installation process. These obstructions typically include power lines, signage or trees.

Required clearance heights for crane lifts should be known prior to undertaking this evaluation.

7.4 Unloading Exclusion Zone & Storage

Only appropriate load-rated slings or chains should be used for safe unloading (ref section 8.3). It is recommended that an exclusion zone be maintained around the unloading process. This provides distance between moving machinery and workers in the event that goods or the machinery move unexpectedly. Unloading and the storing of the product on a level surface is recommended. The Transport frames used to ship CrocGuard beams to site can be used for a safe stable means to store the CrocGuard beams on site (ref drawings pg16). Storing product adjacent to the installation area eliminates the requirement for workers to carry items over long distances.

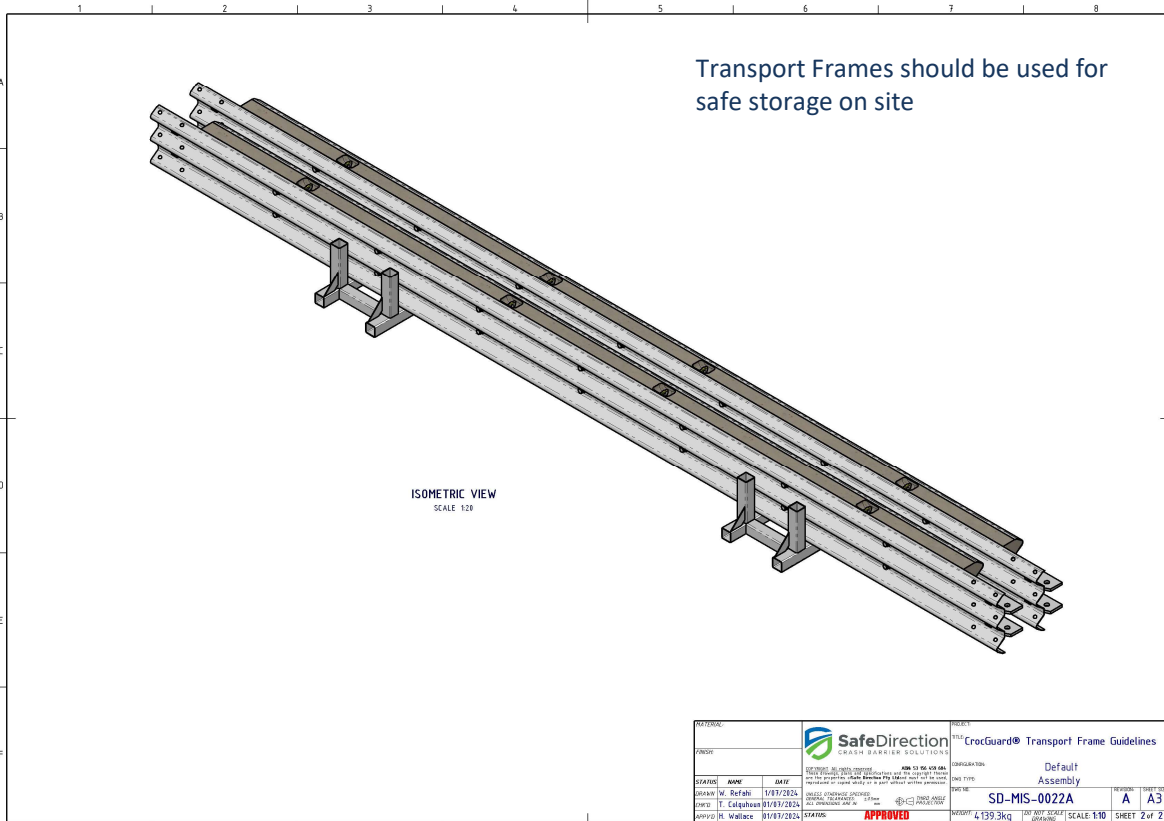

SafeDirection CRASH BARRIER SOLUTIONS		PROJECT: CrocGuard® Transport Frame Guidelines
DESCRIPTION: Default Assembly	REVISION: A	SHEET: 2 of 2
DATE: 01/03/2024	SCALE: 1:20	WEIGHT: 4,139.3kg
APPROVED: M. Wallace	STATUS: APPROVED	

Notes -

1. **Pre-use inspection** - Transport Frames should be inspected prior use. Frames must not be used if there is any damage to the structural elements or welds. The frames must also not be used if there is any distortion to their shape - All SHS Sections are fabricated to an orthogonal construction (90 degrees to adjacent members).
2. Each CrocGuard beam is to be supported by minimum two (2) Transport Frames.
3. Safe Working Load (SWL) of 5t at each slot or 10t for two slots.
4. 8m CrocGuard beam shown for reference only.

REV	DATE	DESCRIPTION	BY
A	01/03/2024	Initial Issue	HW

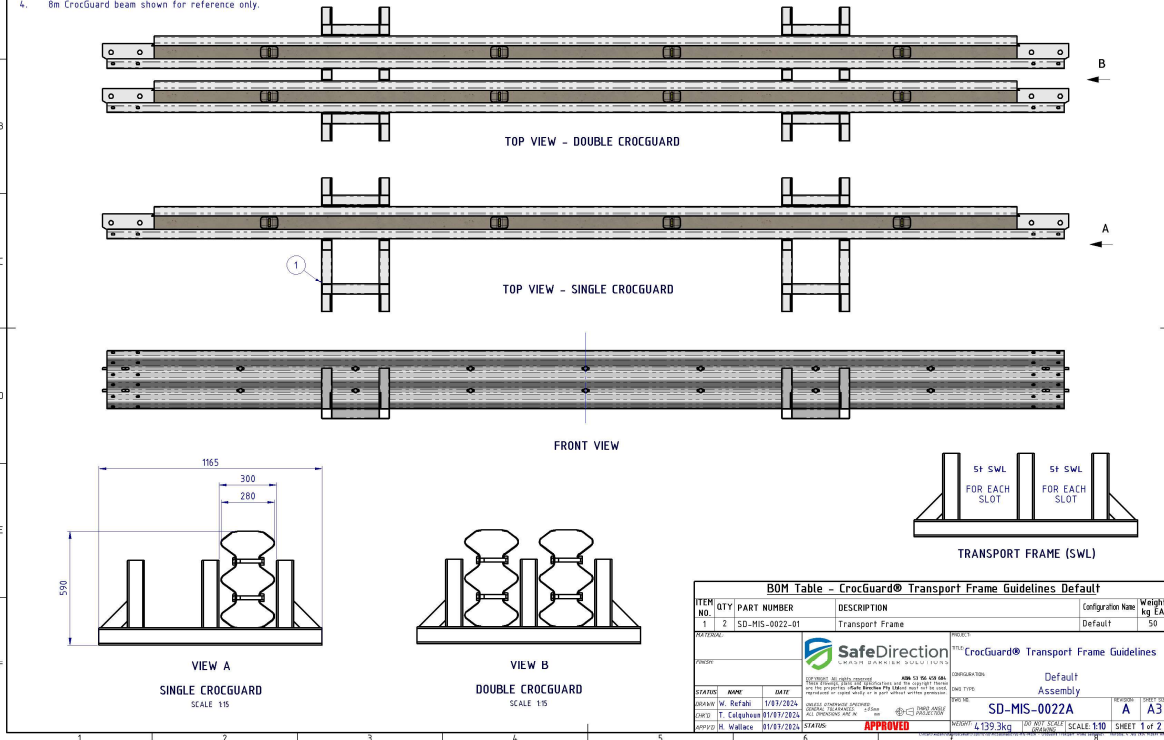

BOM Table - CrocGuard® Transport Frame Guidelines Default					
ITEM NO.	QTY	PART NUMBER	DESCRIPTION	Configuration Name	Weight kg
1	2	SD-MIS-0022-01	Transport Frame	Default	50

SafeDirection CRASH BARRIER SOLUTIONS		PROJECT: CrocGuard® Transport Frame Guidelines
DESCRIPTION: Default Assembly	REVISION: A	SHEET: 1 of 2
DATE: 01/03/2024	SCALE: 1:50	WEIGHT: 4,139.3kg
APPROVED: M. Wallace	STATUS: APPROVED	



7.5 Site Preparation

Installation may take place by lifting CrocGuard® direct from the delivery truck and into position. If however the barrier is to be installed at a separate time to delivery then a set down area will be required and should be prepared in advance.

If being stored, the CrocGuard® beams should be set down on a level surface. CrocGuard® beams are typically shipped to site with cradles for stability. These cradles may be used to stabilise storage on the ground.

8.0 CrocGuard® Installation

The major steps in the installation of CrocGuard® are as follows;

- Set-out;
- Auguring the abutment post holes;
- Lifting the CrocGuard® beams;
- Attachment of the abutment posts;
- Concreting the abutment posts; and
- Installing the RamShield® Transitions.

8.1 Set-out

Mark the location for auguring of holes for the abutment posts. Confirm exact beam length (measure from midpoint between holes of connection plates at each end of the CrocGuard® beam).

Mark a line on the pavement at each end of the installation at a spacing matching the exact length of the CrocGuard® beam measured. Mark a cross point 350mm set back from the desired traffic face of the CrocGuard® – this is the centre point for auguring the abutment post hole.

Augur first hole and then re-check centre line distance to second hole. Adjust positioning for second hole for any movement that may have occurred from first augur hole being kicked off original mark.

8.2 Auguring the Abutment Post Holes

Potential Hazards: Use of auger, contact with underground hazards, excessive noise, deep excavation.

Recommended Control Measures: Observe the safe work instructions as per machinery requirements, ensure the area has been inspected for underground hazards and wear appropriate hearing protection.

Drill a 600mm diameter hole to a depth of 1800mm. If rock or weak soil conditions are encountered, seek advice from Safe Direction.

8.3 Lifting the CrocGuard® Beams

Potential Hazards: Falling of load, swaying of load, contact with above-ground hazards, poor communication and poor visibility.

Recommended Control Measures: Observe the safe work instructions as per machinery requirements, ensure that all slings and chains are appropriately load rated, maintain a safe exclusion zone, only sling from lifting points and establish a clear communication process.

CrocGuard® is supplied as a fully assembled beam with four (4) lifting points. Two (2) lifting points are positioned 3m apart at the centre of the beam. Two (2) further lifting points are each located 1.5m from each end of the beam.

Beams can be lifted from either the two (2) central points or the two (2) outer points. The beam can be lifted with a single or two (2) cranes.

The angle of any lifting chain or sling should not exceed 30 degrees from vertical.

Lifting anchors are all 8.5 tonne rated Reid Swift Lifts regardless of the CrocGuard® beam length. Safe Direction will supply two (2) off Reid Swift Lift Clutches on loan for each project.

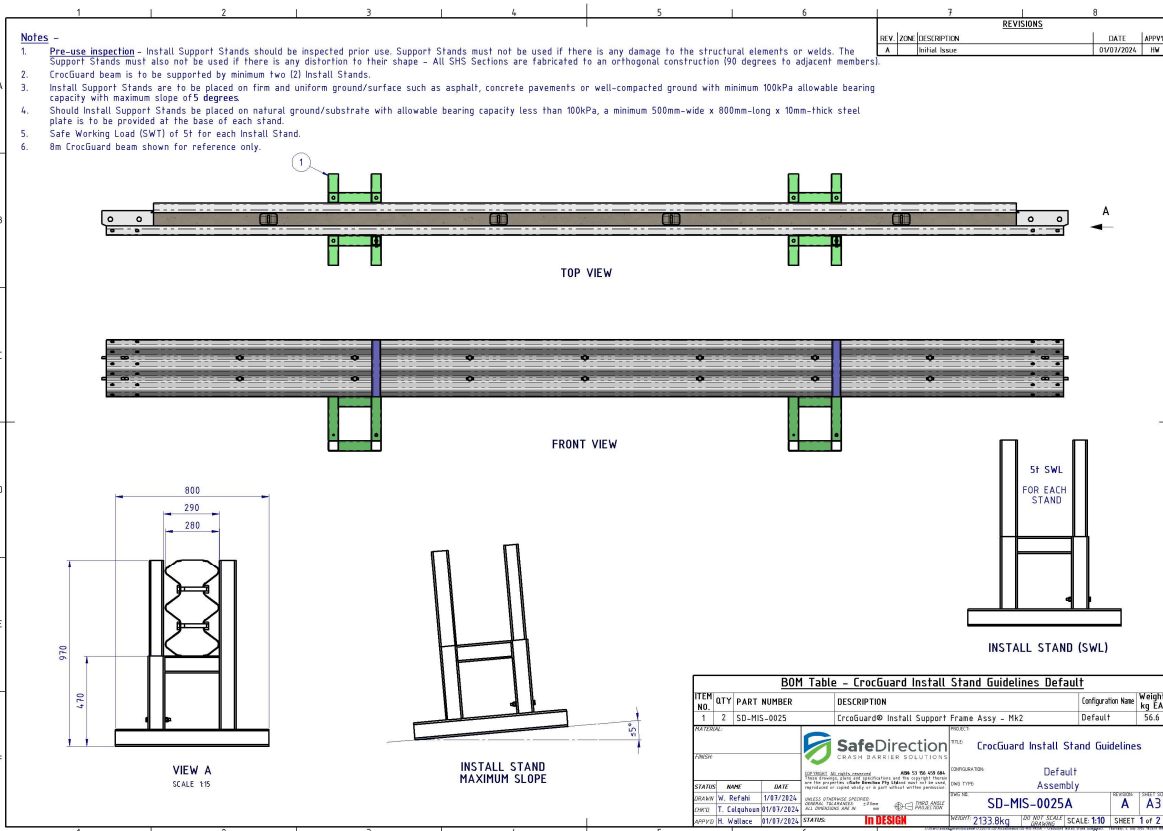
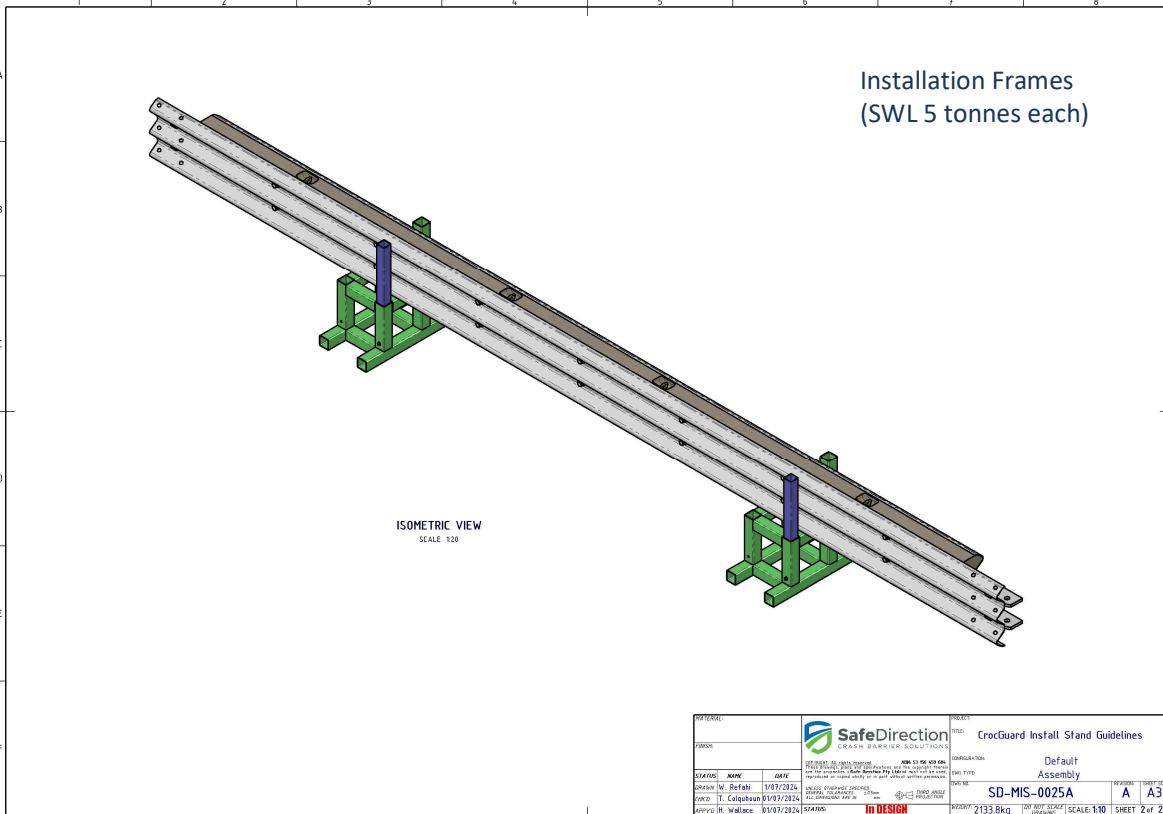



Position the beam adjacent to the excavated abutment post holes and lower onto the support stands supplied by Safe Direction.

The support stands are purposefully designed such that the beam will be just below its installed height. This is to permit chocking to the finish height.

8.4 Attaching the Abutment Post

Potential Hazards: Heavy lifting, hand injury from pinch points and injury from movements and posture

Recommended Control Measures: Use machinery to lift abutment posts, wear gloves and observe correct techniques when lifting (bend at the knees).

Place the post reinforcing cage into the excavated post hole.

Lift the abutment post using a plate clamp and orientate with the connecting brackets on the traffic side.

Lower the abutment post into the hole ensuring the post is positioned within the reinforcing cage.

Align the post connecting brackets with the CrocGuard® brackets and secure with four (4) M36 x 100mm structural bolts, nuts and washers.

The bolt assemblies should be tightened to 100Nm, which can be achieved by hand using a standard-length spanner.

With both abutment posts attached, check the CrocGuard® beam alignment and height. The CrocGuard® beam can be lifted with the abutment posts attached to adjust the height by chocking the support stands.

8.5 Concreting the Abutment Post

Potential Hazards: Heavy machinery, hand injury from pinch points and injury from movements and posture

Recommended Control Measures: Observe the safe work instructions as per machinery requirements, wear gloves and observe correct techniques when lifting (bend at the knees).

Pour 32Mpa concrete into the post hole. The reinforcing cage should be held off the bottom of the hole until sufficient concrete is poured to position the top of the cage 50 to 100mm below finished surface level.

Vibrate the concrete while pouring and trowel the surface once pouring is complete.

Excess concrete may be poured into the abutment post, however this is not required for the performance of CrocGuard®.

It is recommended that the support stands remain for 24 hours to allow the concrete to cure.

8.6 Installing the RamShield® Transition

A RamShield® Transition is required to be installed at each end of the CrocGuard® beam. Refer to the RamShield® Transition Product Manual for assembly guidelines and design considerations.

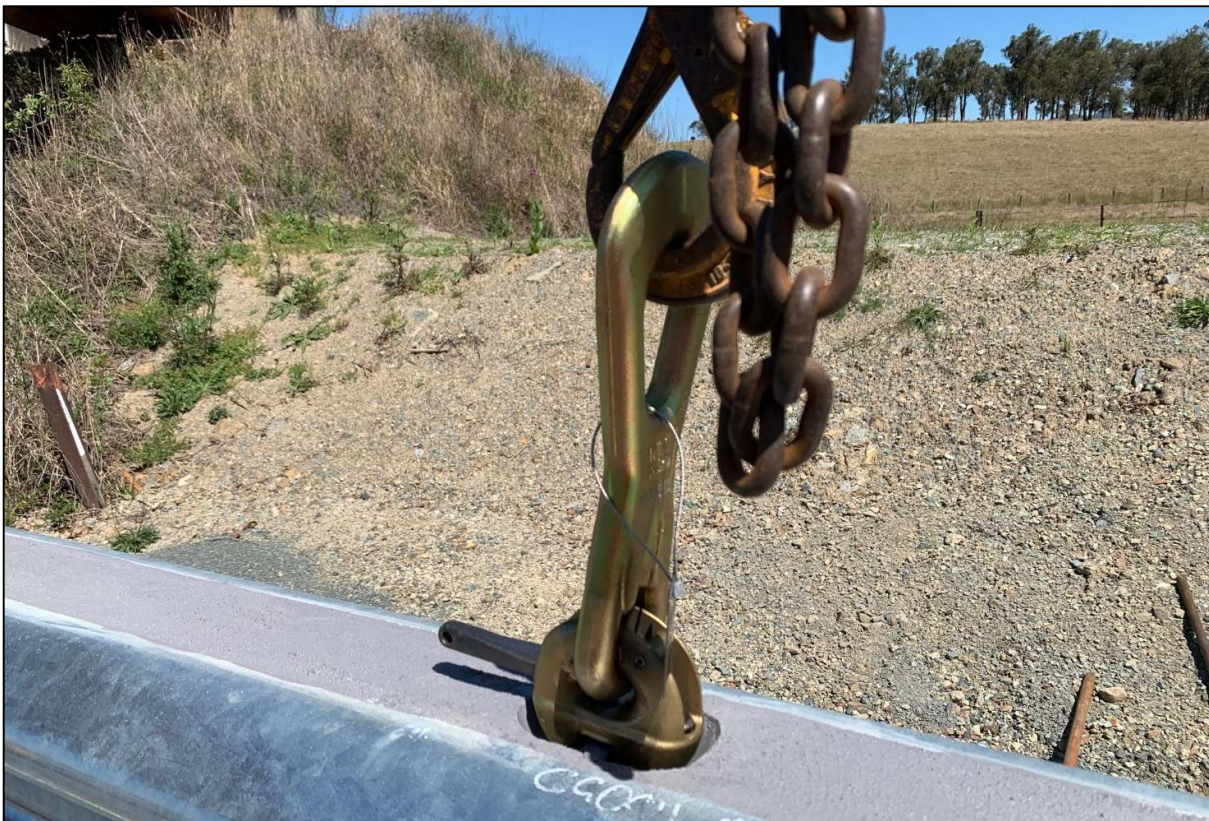

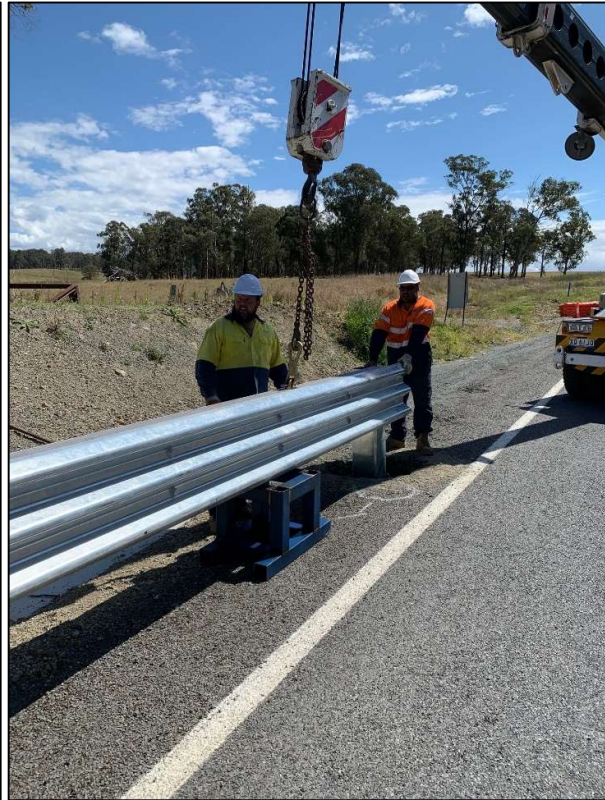



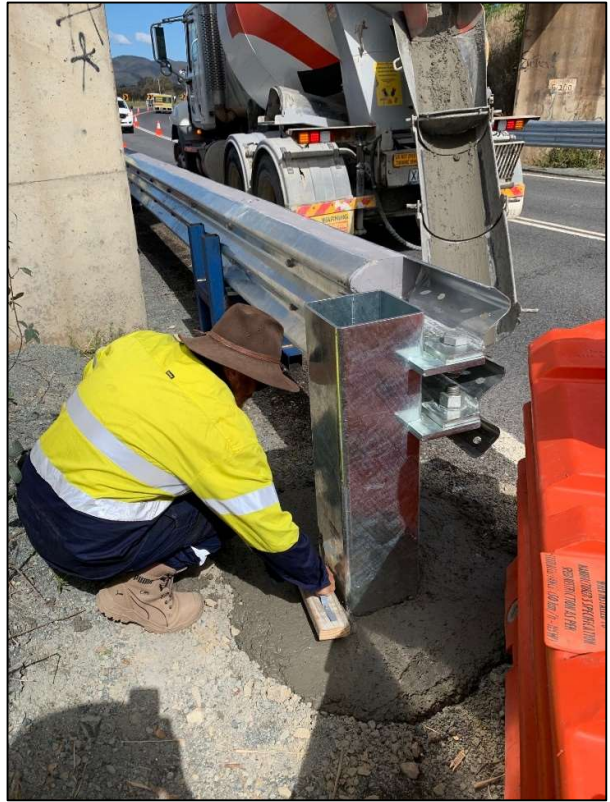





9.0 Maintenance

Crash testing has demonstrated CrocGuard®'s outstanding durability and resistance to damage.

The underlying philosophy in the development of crash test guidelines is that of "worst practical conditions."

Following an impact with a 1100kg passenger car travelling at 100km/h and 25 degrees, the CrocGuard® beam and abutment posts were undamaged and reused for subsequent crash testing.

Bridges and culverts typically have narrow lane widths limiting real-life impacts to shallower angles than crash test conditions.

Periodic inspections of CrocGuard® are recommended to assess the following;

- Debris has not accumulated around the barrier which may impede the function of the barrier

- Vegetation around the barrier is appropriately maintained;
- Nuisance impacts have not gone undetected; and
- The anchor assembly at the end terminals is taut and the bearing plate is correctly aligned.

10.0 Repair

In the event of a vehicle impact, the barrier should be inspected for permanent deformation and concrete cracking.

Onsite repairs to CrocGuard® should be limited to re-compaction of soil around the abutment posts and galvanising damage to the three-beam rail which can be repaired using two (2) coats of a zinc-rich paint.



Figure 8: Nil Damage to CrocGuard® Following MASH 4-10 Impact